

Refer to Topic 6.2.6 for a detailed explanation of the properties of concrete, types and causes of concrete deterioration, and the examination of concrete.

9.11.4

Inspection Methods and Locations

Inspection methods to determine other causes of concrete deterioration are presented in detail in Topic 6.2.8.

Methods

Visual

The inspection of prestressed concrete box girders for surface cracks, spalls, and other deficiencies is primarily a visual activity.

Physical

Sounding by hammer can be used to detect delaminated areas. A delaminated area will have a distinctive hollow "clacking" sound when tapped with a hammer or revealed with a chain drag. A hammer hitting sound concrete will result in a solid "pinging" type sound. In most cases, a chain drag is used to check the top surface of a concrete deck or top flange.

Since prestressed box girders are designed to limit tensile stresses in concrete to specified thresholds, cracks are indications of serious problems. For this reason, carefully measure any crack with an optical crack gauge or crack comparator card and document the results.

Advanced Inspection Methods

Several advanced methods are available for concrete inspection. Nondestructive methods, described in Topic 15.2.2, include:

- Acoustic wave sonic/□ultrasonic velocity measurements
- Electrical methods
- Delamination detection machinery
- Ground-penetrating radar
- Electromagnetic methods
- Pulse velocity
- Flat jack testing
- Impact-echo testing
- Infrared thermography
- Laser ultrasonic testing
- Magnetic field disturbance
- Neutron probe for detection of chlorides
- Nuclear methods
- Pachometer
- Rebound and penetration methods
- Ultrasonic testing
- Radiography

- Smart concrete
- Carbonation

Other inspection methods or tests for material properties, described in Topic 15.2.3, include:

- Concrete permeability
- Concrete strength
- Endoscopes and videoscopes
- Moisture content
- Petrographic examination
- Reinforcing steel strength
- Chloride test
- Matrix analysis
- ASR evaluation

Locations – Concrete Box Girder

The inspection of a box girder bridge requires a clear understanding of the girder function. This requires a thorough review of design or as-built drawings prior to the inspection and a realization of the high stress regions in a particular structure. Because of the complexities of box girders, many agencies develop an inspection and maintenance manual for a structure, which is written by the structural designer.

Arguably, the most important inspection a box girder will receive is the first or initial inspection. This inspection will serve as a benchmark for all future inspections. Since the initial inspection is so important, schedule it as early as possible after the construction of the bridge. Because of the complex nature of the box girder, all surfaces on the interior and exterior of the girder require visual examination.

Bearing Areas

Check the bearing area for delaminations, spalls and cracks. Delaminations, spalls and cracks may be caused by corrosion of steel reinforcement due to water leakage or restriction of thermal movements.

The effects of temperature, creep, and concrete shrinkage may produce undesirable conditions at the bearings. Check the bearing areas and the bearings for proper movement and movement capability (see Figure 9.11.28).



Figure 9.11.28 Bearing Area of a Box Girder Bridge

Shear Zones

Check girder ends and sections close to piers for diagonal shear cracks in webs. These web cracks will project diagonally upward at approximately a 45 degree angle from the support toward midspan (see Figure 9.11.29).

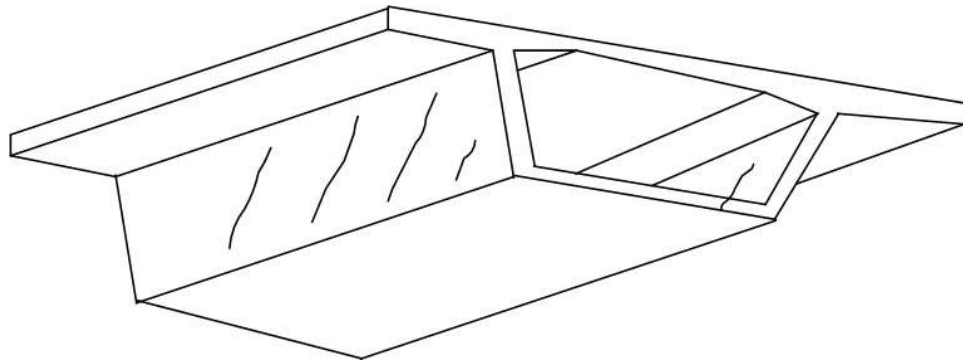

Figure 9.11.29 Box Girder Cracks Induced by Shear

Tension Zones

Direct Tension - Tension cracks can appear as a series of parallel cracks running transverse to the longitudinal axis of the bridge. The duct cracks are normally located on both sides of the longitudinal or neutral axis. The cracks can possibly be through the entire depth of the box girder section. Cracks will probably be spaced at approximately 1 to 2 times the minimum thickness of the girder component (see Figure 9.11.30).

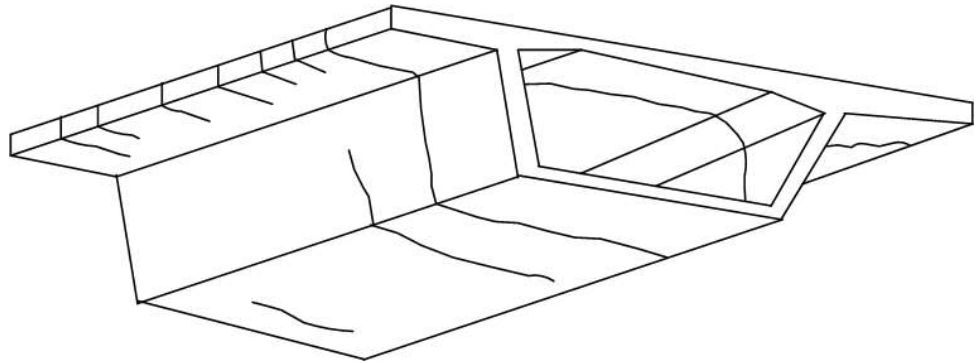

Figure 9.11.30 Box Girder Cracks Induced by Direct Tension

Flexure - These cracks can appear in the top flange at pier locations and on the bottom flange at mid-span regions. The extent of cracking will depend on the intensity of the bending being induced. Flexure cracks will normally propagate to the neutral axis or to an area around the half-depth of the section. Examine flexural cracks found in post-tensioned members very carefully. This could indicate that the member is overstressed. Accurately identify the location of the crack, the length and width of the crack, and the spacing to adjacent cracks (see Figures 9.11.31 and 9.11.32).

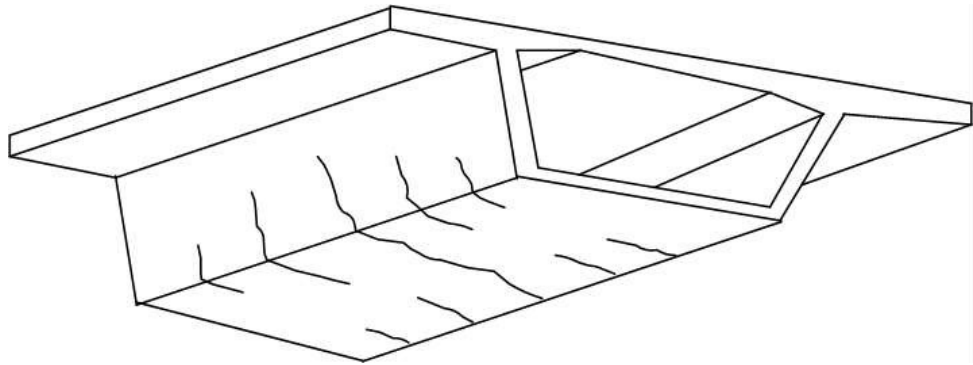

Figure 9.11.31 Box Girder Cracks Induced by Flexure (Positive Moment)

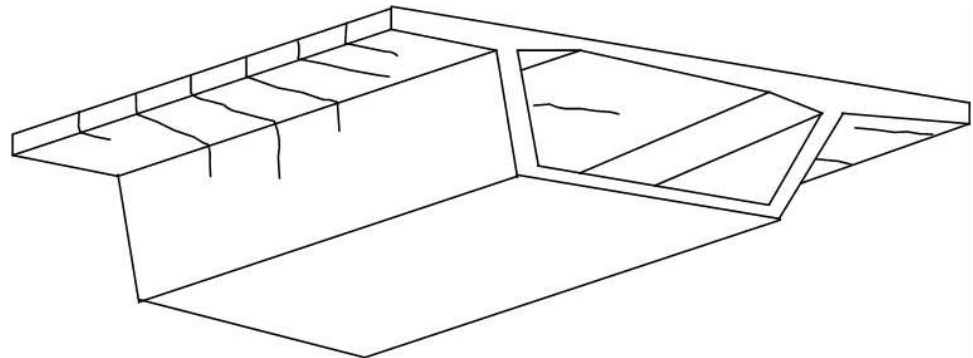

Figure 9.11.32 Box Girder Cracks Induced by Flexure (Negative Moment)

Flexure-shear - These cracks can appear close to pier support locations. They initiate on the bottom flange oriented transverse to the longitudinal axis of the bridge. The cracking will propagate up the webs approximately 45 degrees to the horizontal and toward mid-span (see Figure 9.11.33).

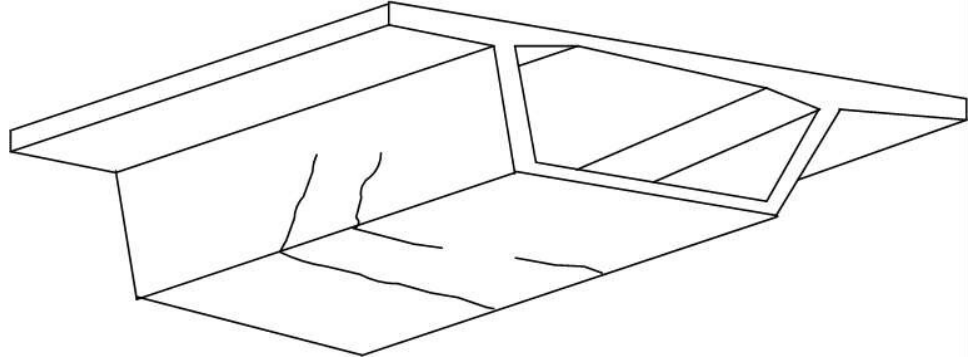

Figure 9.11.33 Box Girder Cracks Induced by Flexure-shear

Inspect the top side of the top flange for longitudinal flexure cracking directly over interior and exterior girder webs. Inside the box, examine the bottom of the top flange for longitudinal flexure cracking between the girder webs. These longitudinal cracks are caused by overstressing of the deck. Document any efflorescence or leakage through the top flange.

Inspect the girder throughout for flexure and shear cracks as well as prestress-induced cracks. Some shrinkage cracks are to be expected. Likewise, although post-tensioned, some small cracks may be present. As with all prestressed concrete members, carefully measure any cracks with an optical crack gauge or crack comparator and document its location, length, width, and crack spacing.

Anchor Blocks

Anchor blocks (or blisters) contain the termination of the post-tensioning tendons. Very large concentrated loads are developed within these blocks. They have a tendency to crack if not properly reinforced or if there are voids adjacent to the post-tensioning tendons. The cracking will be more of a splitting failure in the web and would be oriented in the direction of the post-tensioning tendon (see Figure 9.11.34).

Deviation Blocks

Also known as "deviation saddles", deviation blocks allow longitudinal post-tensioning tendons to change direction or angle within the box girder (see Figures 9.11.35 and 9.11.47). Deviation blocks allow free longitudinal movement through the ducts, while still acting as holding points for the longitudinal post-tensioning tendons. Additionally, deviation blocks may be used with temporary post-tensioning tendons to maintain alignment of the tendon (see Figure 9.11.36). As with anchor blocks, carefully examine deviation blocks since these are points of very high stress concentrations. Locating and identifying areas of delamination, spalling and cracking is essential due to the structural importance of this component.

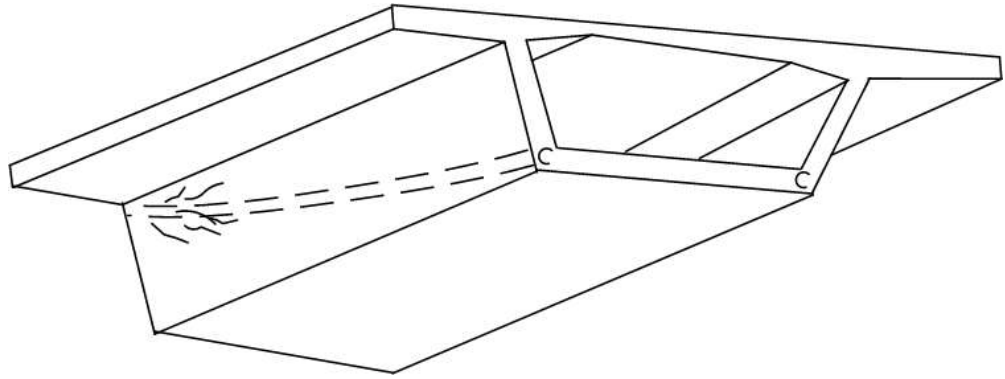

Figure 9.11.34 Web Splitting near an Anchorage Block



Figure 9.11.35 Deviation Block Used as a Hold-Down Point for External Post-Tensioning



Figure 9.11.36 Temporary Deviation Blocks Used to Maintain Tendon Alignment During Construction

Internal Diaphragms

Internal diaphragms at the piers and abutments serve to stiffen the box section and to distribute the large bearing reaction loads. Tendon anchorages located within the diaphragm will also contribute to additional post-tensioning loads. This region of the structure is very highly stressed and, therefore, prone to crack development. The internal diaphragms require close examination during inspection (see Figure 9.11.48).

Secondary Members

If there are external diaphragms between the girders, check for delaminations, spalls and cracking. Deficiencies on end diaphragms may indicate differential substructure settlement while deficiencies in the intermediate diaphragms may indicate excessive deflection in the girders.

Areas Exposed to Drainage

Examine the box girder for any delaminations, spalling, or scaling which may lead to exposure of reinforcing steel. Give special attention to areas such as joints, scuppers and curb lines exposed to drainage.

Drain Holes

Drain holes are typically provided at the low point of each box girder "cell" (see Figure 9.11.37). They function to allow water to drain from inside the box girder. To prevent the entrance of unwanted wildlife, screens are often placed on the inside of the box girder. Inspect these devices for missing screens or clogging due to debris.



Figure 9.11.37 Concrete Box Girder Drain Hole with Screen

Areas Exposed to Traffic

Check areas damaged by collision. A significant amount of concrete box girder bridge deterioration and loss of section is due to traffic damage. Document the number of exposed tendons, the length of exposed tendons, number of severed strands, the extent of, as well as the loss of, concrete section. The loss of concrete due to such a collision is not always serious, unless the bond between the concrete and steel reinforcement is affected.

Inspection of the roadway surface for delaminations, cracking, spalling, and deformation; the presence of these deficiencies can increase the impact effect of traffic. This may be of greater significance if the top flange does not have an added wearing surface.

Areas Previously Repaired

Examine thoroughly any repairs that have been previously made. Determine if repaired areas are sound and functioning properly. Effective repairs and patching are usually limited to protection of exposed tendons and reinforcement.

Other Areas Exposed to External Damage

- Waterborne debris or ice
- Fire
- Equipment hits
- Displacement of superstructure due to floods, storm surges, etc.

Post-Tensioned Grout Pockets

Check the condition of the lateral post-tensioning grout pockets and visible ends of the post-tensioning rods. Cracked grout or rust stains may indicate a failure of the post-tensioning rod or loss of monolithic action.

Camber

Check the camber of the box girders. Loss of positive camber indicates loss of prestress in the tendons.

Miscellaneous Areas

Cracks Caused by Torsion and Shear - This type of cracking will occur in both the flanges and webs of the box girder due to the twisting motion induced into the section. This cracking is very similar to shear cracking and will produce a helical configuration if torsion alone was present. Bridge structures most often will not experience torsion alone; rather bending, shear and torsion will occur simultaneously. In this event, cracking will be more pronounced on one side of the box girder due to the additive effects of all forces (see Figure 9.11.38).

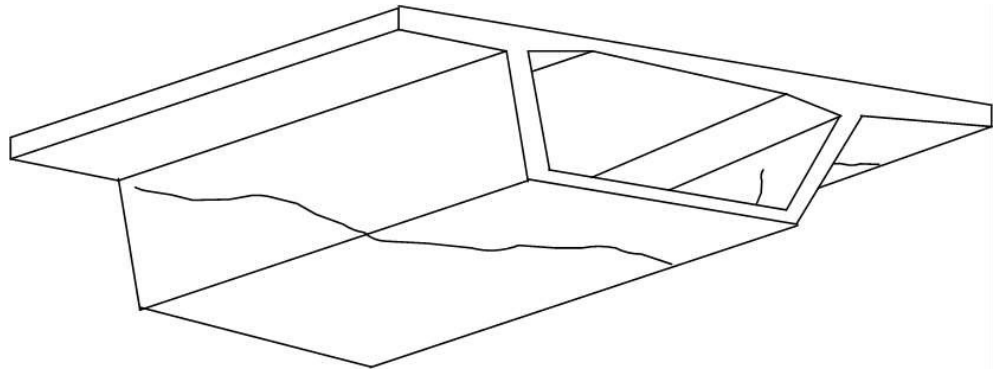

Figure 9.11.38 Box Girder Cracks Induced by Torsion and Shear

Thermal Effects - These cracks are caused by non-uniform temperatures between two surfaces located within the box girder. Cracking will typically be transverse in the thinner flanges of the box and longitudinal near changes in cross section thickness (see Figures 9.11.39 and 9.11.40).

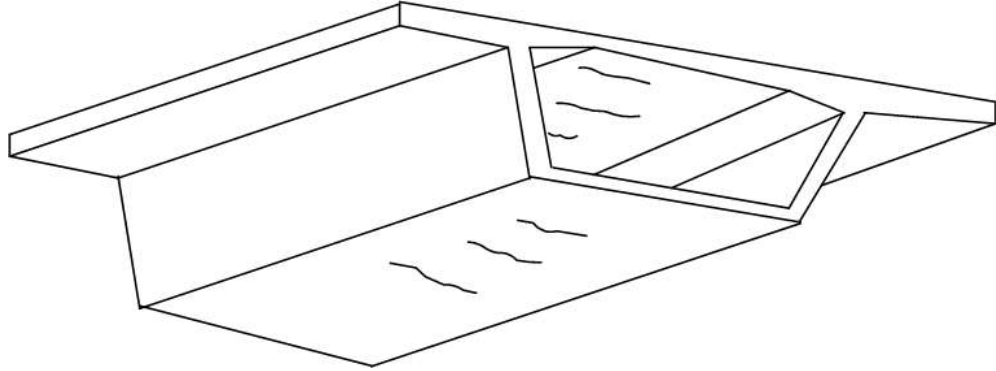

Figure 9.11.39 Thermally Induced Transverse Cracks in Box Girder Flanges

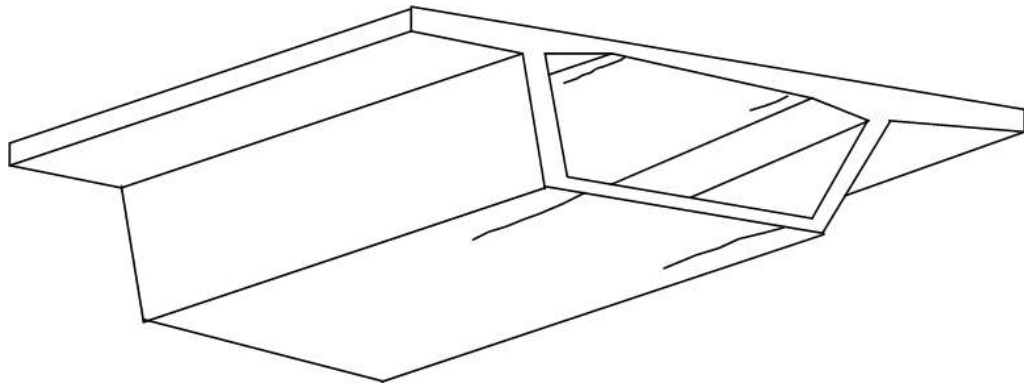

Figure 9.11.40 Thermally Induced Longitudinal Cracks at Change in Box Girder Cross Section

Post-tensioning - Cracking can occur along any of the lines of post-tensioning tendons. For this reason it is important for the inspector to be aware of where tendons are located in the box section (see Figures 9.11.34 and 9.11.41). This cracking may be the result of a bent tendon, a misaligned tendon with insufficient concrete cover or voids around the tendons. Shrinkage of concrete adjacent to large tendons has also caused this type of cracking.

In older post-tensioned bridges, problems due to insufficient grout placement in the conduit around the tendon have been reported. These voided areas can fill with water and the water will accelerate corrosion of the post-tensioning strands. In colder climates, the water may freeze and burst the conduit and surrounding concrete. Radiography and other nondestructive testing methods have been used successfully to locate these voids. These methods are also used to determine if the voids are present during construction of present-day bridges. If voids are found during construction, additional grout is added to eliminate these voids. States such as Florida have revised their polices for grouting materials and methods to eliminate these problems in bridges currently being constructed.



Figure 9.11.41 Post-tensioning Tendon Duct

Unintentional load path - Inspect older cast-in-place box girder interiors to verify that inside forms left in place do not provide unintentional load paths, which may result in overloading elements of the box (see Figure 9.11.42). Loads from the deck may be directly transferred to the bottom flange. This was not the intent of the original design.



Figure 9.11.42 Interior Formwork Left in Place

Structure Alignment - An engineering survey needs to be performed at the completion of construction and a schedule for future surveys established. The results of these surveys will aid the bridge engineer in assessing the behavior and performance of the bridge. Establish permanent survey points at each substructure and at each mid-span. Likewise, several points need to be set at each of these locations in the transverse direction across the deck (see Figure 9.11.43). During the inspection:

- Inspect the girder for the proper camber by sighting along the fascia of the bottom flange.
- On curved box girders, check for irregularities in the superelevation of the flanges, which could indicate torsional distress.

Radial Cracking - Post-tensioning tendons can be aligned vertical, horizontal or both depending on the vertical and horizontal geometry of the finished structure. The tendons produce a component of force normal to the curvature of their alignment. The result of this force can be cracking or spalling of the concrete components that contain these tendons. This type of distress is localized to the tendon in question, but can occur virtually anywhere along the length of the tendon. Joints of match cast precast segments are particularly sensitive to this type of cracking.

Investigate unusual noises, such as banging and screeching, which may be a sign of structural distress.

Observe and record data from any monitoring instrumentation (e.g., strain gauges,

(displacement meters, or transducers) that has been installed on or within the bridge.

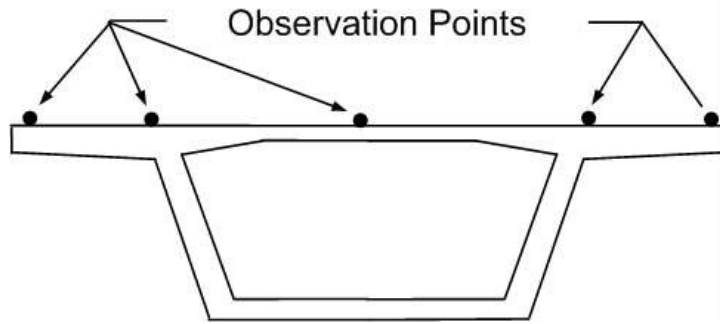

Figure 9.11.43 Location of Observation Points Across the Top Flange

**Locations -
Segmental Box
Girder**

In addition to the inspection locations and methods for concrete box girders, there are several special components that are unique to segmental bridges. The bridge inspector needs to be familiar with these special components.

Inspecting a segmental box girder bridge is similar to the methods mentioned previously. This is described in Topic 6.2.8 and this format is consistent with similar topics. for concrete box girders, and includes the following specific methods:

Bearing Areas

Due to the inherent behavior of prestressed concrete structures, the effects of temperature, creep and shrinkage of the concrete may produce undesirable conditions to the bearings. These undesirable conditions take the form of distorted elastomeric bearings or loss of movement to mechanical bearings. Additionally, the areas where bearings interface with the bottom flange of the box girder need special attention. Large vertical forces from the superstructure are required to be transmitted to the bearings and, therefore, sizable bearing stresses are produced in these areas (see Figure 9.11.44).



Figure 9.11.44 Segmental Box Girder Bearings at Intermediate Pier

Shear and Tension Zones

Inspect both the interior and the exterior surfaces of the box girder. The inspection methods for shear and tension zones in segmental box girder bridges are the same as for concrete box girder bridges. Examples of cracking in segmental box girder bridges are shown in Figures 9.11.29 to 9.11.34 and Figures 9.11.38 to 9.11.40.

Anchor Blocks

Segmental construction relies on the tremendous post-tensioning forces to hold the individual segments together. Inspection of anchor blocks for segmental box girder bridges is the same as for concrete box girder bridges. Additionally, the inspection needs to focus on the box girder webs adjacent to the anchor blocks and look for the development of vertical cracks on either side of the anchors. Examine the condition of the tendons adjacent to the anchor blocks. The flange or web on which the anchor block is located will require attention concerning the potential for transverse cracking in the vicinity of the anchor (see Figure 9.11.45).

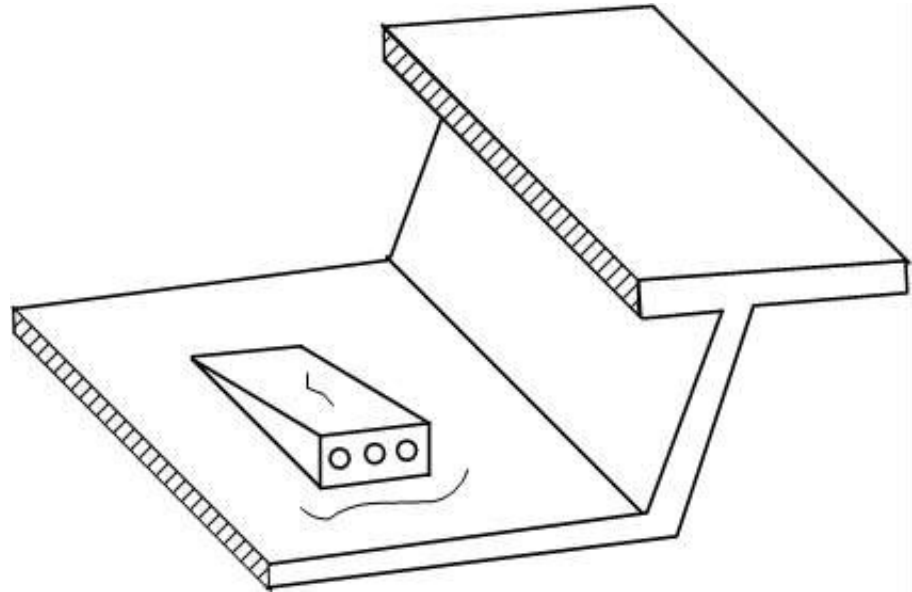

Figure 9.11.45 Segmental Box Girder Cracks Adjacent to Anchorage Block

Deviation Blocks

As with cast-in-place concrete box girder bridges, segmental construction often relies on draped or "harped" strand patterns to counter negative moment near intermediate supports. Deviation blocks (or saddles) are used to change the direction or angle of longitudinal post-tensioning tendons while allowing free longitudinal movement through the duct (see Figures 9.11.35 and 9.11.47). Additionally, deviation blocks may be used with temporary post-tensioning tendons to maintain alignment of the tendon (see Figure 9.11.36). Inspection of deviation blocks for segmental box girder bridges is the same as for concrete box girder bridges.

Secondary Members

Internal diaphragms are located at abutments and piers. Closely examine these members including the tendon anchorages located within them. The diaphragms stiffen the box section and distribute large bearing reaction loads. Examine this high stress region closely for cracks.

If there are external diaphragms between the box girders, check for cracking and spalling. Deficiencies on end diaphragms may indicate differential substructure settlement while deficiencies in the intermediate diaphragms may indicate excessive deflection in the girders.

Joints

Inspect joints for crushing and movement of the shear keys (see Figures 9.11.15 and 9.11.46). The presence of open or loose joints needs to be documented. Areas where the type of construction required closure joints or segments to be poured in place will need close attention. These areas sometimes are regions of tendon anchorages and couplers. The stress concentrations in these areas are very much different than a section away from the anchorages where a distributed stress pattern exists (see Figure 9.11.47).

Additionally, the effects of creep and tendon relaxation are somewhat higher in these regions.

Closely examine the joints between the segments for any signs of leakage or infiltration.



Figure 9.11.46 Close-up View of Box Girder Joint

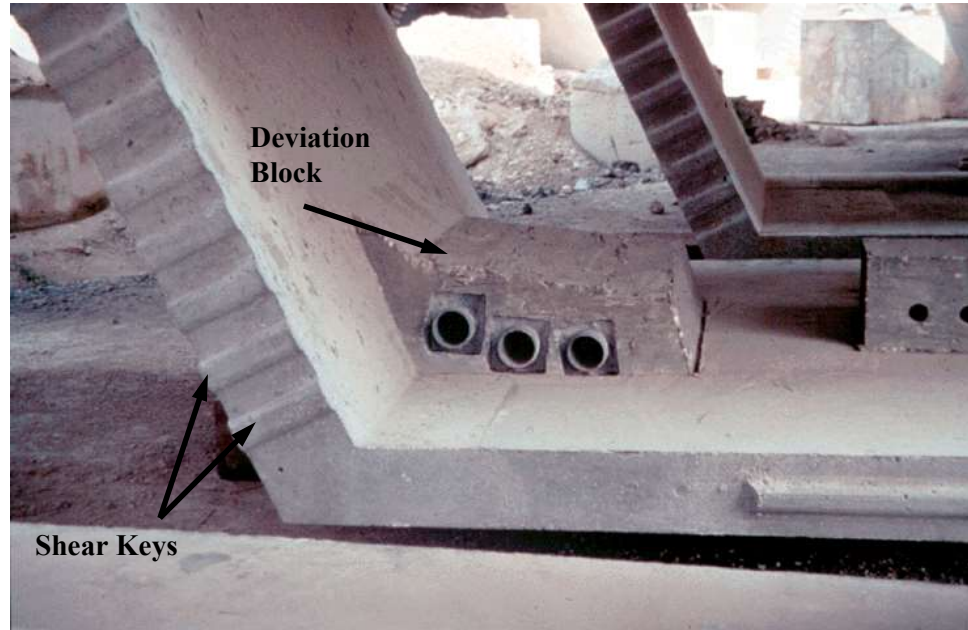

Figure 9.11.47 View of Box Girder Joint (Shear Keys) and Deviation Block

Internal Diaphragms

Internal diaphragms at the piers and abutments serve to stiffen the box section and to distribute the large bearing reaction loads. Tendon anchorages located within the diaphragm will also contribute to additional post-tensioning loads. This region of the structure is very highly stressed and, therefore, prone to crack development. The internal diaphragms require close examination during inspection (see Figure 9.11.48).



Figure 9.11.48 Box Girder Interior Diaphragm and Post-Tensioning Ducts

Areas Exposed to Drainage

Inspection of areas exposed to drainage is the same as those for concrete box girder bridges.

Closely examine the joints between the segments for any signs of leakage or infiltration.

Drain Holes

Inspection of drain holes is the same as those for concrete box girder bridges.

Areas Exposed to Traffic

Inspection of areas exposed to traffic is the same as those for concrete box girder bridges.

Areas Previously Repaired

Inspection of previous repairs is the same as those for concrete box girder bridges.

Other Areas Exposed to External Damage

- Waterborne debris or ice
- Fire
- Equipment hits
- Displacement of superstructure due to floods, storm surges, etc.

Post-Tensioned Grout Pockets

Inspection of post-tensioned grout pockets is the same as those for concrete box girder bridges.

Camber

Inspection for camber and vertical alignment is the same as those for concrete box girder bridges.

Miscellaneous Areas

Cracks caused by torsion and shear are the same as those for concrete box girder bridges.

Cracking within post-tensioning tendon areas (lines) are the same as for concrete box girder bridges.

Radial cracking is the same as for concrete box girder bridges.

Thermal Effects - The effects of temperature and the appropriate inspection methods to accommodate for it is the same as those for concrete box girder bridges. Additionally, these cracks can also occur at component changes in thickness such as that between a web and a flange. In this case the cracking will occur at the juncture between these two elements.

9.11.5

Evaluation

State and Federal rating guideline systems have been developed to aid in the inspection of concrete superstructures. The two major rating guideline systems currently in use are the FHWA's *Recording and Coding Guide for the Structural Inventory and Appraisal of the Nation's Bridges* used for the National Bridge Inventory (NBI) component condition rating method and the AASHTO *Guide Manual for Bridge Element Inspection* for element level condition state assessment.

NBI Component Condition Rating Guidelines

Using NBI component condition rating guidelines, a one-digit code on the Federal Structure Inventory and Appraisal (SI&A) sheet indicates the condition of the superstructure. Component condition rating codes range from 9 to 0, where 9 is the best rating possible. See Topic 4.2 (Items 58 and 59) for additional details about NBI component condition rating guidelines.

Consider previous inspection data with current inspection findings to determine the correct component condition rating.

Element Level Condition State Assessment

In an element level condition state assessment of a concrete box girder bridge, possible AASHTO National Bridge Elements (NBEs) and Bridge Management Elements (BMEs) are:

<u>NBE No.</u>	<u>Description</u>
<u>Decks/Slabs</u>	
15	Prestressed/Reinforced Concrete Top Flange* * Note that this element designation is used regardless of the type of riding surface
<u>Superstructure</u>	
104	Prestressed Concrete Closed Web/Box Girder
<u>BME No.</u>	<u>Description</u>
<u>Wearing Surfaces and Protection Systems</u>	
520	Deck/Slab Protection Systems
521	Concrete Protective Coating

The unit quantity for the top flange (deck), protection systems and protective coating is square feet. The total area is distributed among the four available condition states depending on the extent and severity of the deficiency (see Figure 9.11.49). The unit quantity for the box girder is feet, and the total length is distributed among the four available condition states depending on the extent and severity of the deficiency. The sum of all condition states equals the total quantity of the National Bridge Element or Bridge Management Element. Condition State 1 is the best possible rating. See the AASHTO *Guide Manual for Bridge Element Inspection* for condition state descriptions.

The following Defect Flags are applicable in the evaluation of concrete box girder superstructures:

<u>Defect Flag No.</u>	<u>Description</u>
358	Concrete Cracking
359	Concrete Efflorescence
362	Superstructure Traffic Impact (load capacity)

See the AASHTO *Guide Manual for Bridge Element Inspection* for the application of Defect Flags.

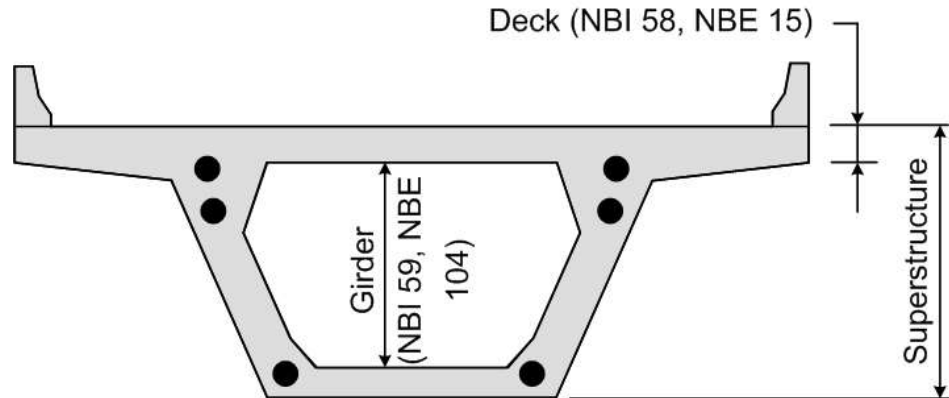

Figure 9.11.49 Components/Elements for Evaluation

Table of Contents

Chapter 10 Inspection and Evaluation of Steel Superstructures

10.1	Rolled Steel Multi-Beams and Fabricated Steel Multi-Girders	10.1.1
10.1.1	Introduction.....	10.1.1
10.1.2	Design Characteristics.....	10.1.1
	Rolled Multi-Beam.....	10.1.1
	Fabricated Multi-Girder.....	10.1.3
	Haunched Girder Design	10.1.7
	Function of Stiffeners	10.1.8
	Primary and Secondary Members	10.1.9
	Fracture Critical Areas	10.1.10
10.1.3	Overview of Common Deficiencies.....	10.1.11
10.1.4	Inspection Methods and Locations	10.1.11
	Methods.....	10.1.11
	Visual	10.1.11
	Physical	10.1.11
	Advanced Inspection Methods.....	10.1.12
	Locations	10.1.13
	Bearing Areas.....	10.1.13
	Shear Zones.....	10.1.13
	Flexure Zones.....	10.1.13
	Secondary Members.....	10.1.16
	Areas Exposed to Drainage.....	10.1.17
	Areas Exposed to Traffic	10.1.18
	Problematic Details.....	10.1.19
	Fracture Critical Members	10.1.19
10.1.5	Evaluation	10.1.20
	NBI Component Condition Rating Guidelines.....	10.1.20
	Element Level Condition State Assessment.....	10.1.20

This page intentionally left blank.

Chapter 10

Inspection and Evaluation of Steel Superstructures

Topic 10.1 Rolled Steel Multi-Beams and Fabricated Steel Multi-Girders

10.1.1

Introduction

The two basic steel superstructure types, rolled steel multi-beams and fabricated steel multi-girders, have similar characteristics; however, there are some primary differences that make each superstructure type unique.

One of the simplest differences is the terminology. Although many designers and inspectors use the terms “beam” and “girder” interchangeably, there is a difference. In steel fabrication, the word "beam" refers to rolled shapes, while the word "girder" refers to fabricated members. Girders are fabricated from web and flange plates.

Rolled beams are generally “compact” sections that satisfy ratios for the flange and web thicknesses to prevent buckling. Rolled beams come in a number of different sizes with each size having specific dimensions for the width and thickness for both the flange and web. These dimensions are standard and can be found in a number of publications, such as the Steel Construction Manual published by the American Institute of Steel Construction, Inc. Also, rolled beams may have bearing stiffeners but typically do not include intermediate stiffeners.

Fabricated girders are different from rolled beams in that they are custom made for specific bridge site conditions. The width and thickness of the flanges and webs can be varied to the necessary dimensions to optimize the design. Fabricated girders generally have both bearing stiffeners and intermediate stiffeners.

10.1.2

Design Characteristics

Rolled Multi-Beam

The steel rolled multi-beam bridge is a configuration of three or more parallel rolled beams with a deck placed on top of the beams. The most common use of this superstructure type is for simple spans, with span lengths from 30 to 50 feet (see Figure 10.1.1). Continuous span designs have also been used, some of which incorporate pin-and-hanger connections (see Figure 10.1.2). Rolled beams are manufactured in structural rolling mills from one piece of steel (i.e., the flanges and web are manufactured as an integral unit). Rolled beams in the past were

generally available no deeper than 36 inches in depth but are now available from some mills as deep as 44 inches.



Figure 10.1.1 Simple Span Rolled Multi-Beam Bridge



Figure 10.1.2 Continuous Span Rolled Multi-Beam Bridge with Pin & Hanger

In the past, a common method of economically increasing the capacity of a rolled multi-beam bridge was to weld partial length cover plates to the flanges (see Figure 10.1.3). The cover plates increased a beam's bending strength. This practice also creates a problematic detail in the tension flange. The cover plates are attached by riveting or welding. Fatigue cracking has been found to occur in the beam flanges at the ends of partial length cover plates.



Figure 10.1.3 Rolled Multi-Beam Bridge with a Cover Plate

Fabricated Multi-Girder The steel fabricated multi-girder bridge is similar to the rolled multi-beam bridge in appearance. However, fabricated girders are often larger than those that could be provided by the rolling mills. Older fabricated multi-girders are riveted or bolted built-up members consisting of angles and plates (see Figure 10.1.4). In a riveted or bolted built-up member, the angles are considered part of the flange. Today's fabricated multi-girders are usually welded plate members (see Figure 10.1.5).

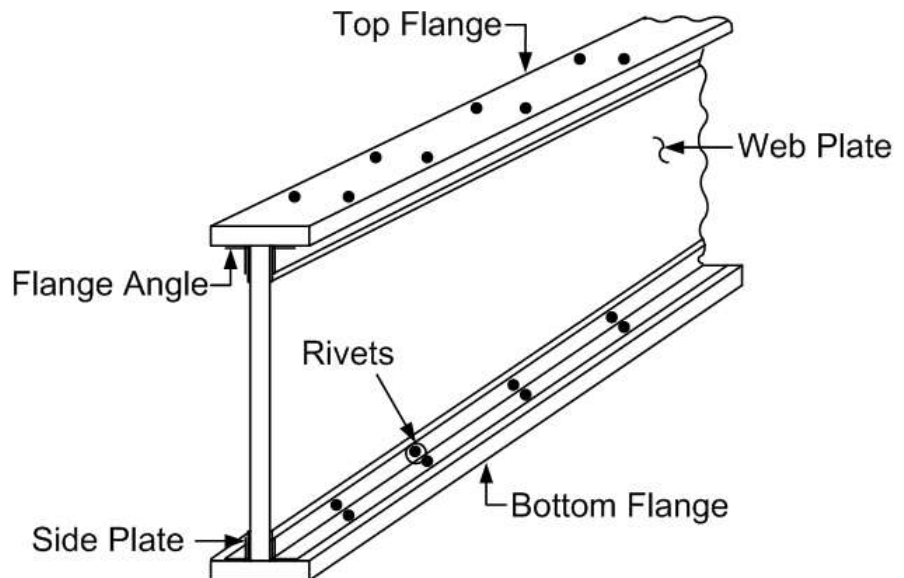

Figure 10.1.4 Built-up Riveted Plate Girder

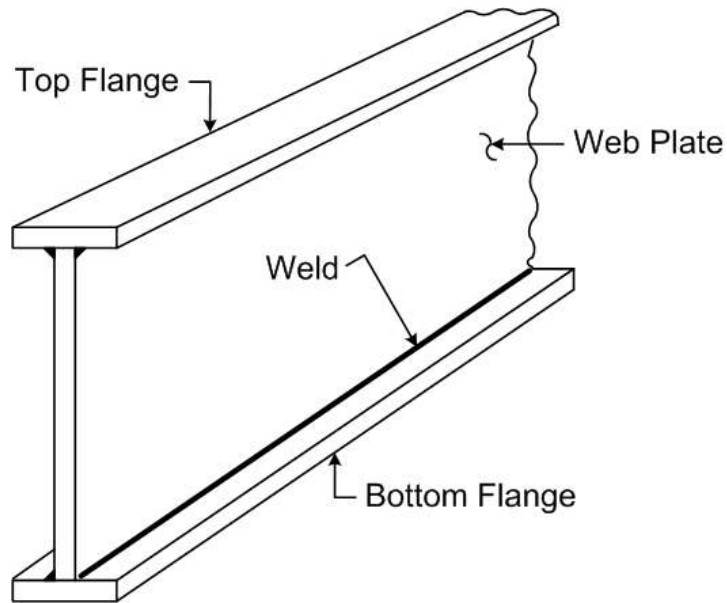

Figure 10.1.5 Welded Plate Girder

This bridge type can be found in single span (see Figure 10.1.6), multiple span, and continuous span designs (see Figure 10.1.7), and it is widely used when curved bridges are required (see Figure 10.1.8). Continuous welded multi-girders have been built for spans of over 500 feet. Pin-and-hanger connections are found in older multi-girder construction (see Figure 10.1.9). This type of connection is not used in modern bridge design practices due to excessive corrosion within the pin-and-hanger assembly which may lead to failure of the connection and girders. Pin-and-hanger assemblies are discussed in detail in Topic 10.7.



Figure 10.1.6 Single Span Fabricated Multi-girder Bridge



Figure 10.1.7 Continuous Span Fabricated Multi-girder Bridge



Figure 10.1.8 Curved Fabricated Multi-girder Bridge

Fabricated multi-girder bridges have three or more primary load paths (girders). Two-girder bridge systems are presented in Topic 10.2.



Figure 10.1.9 Fabricated Multi-girder Bridge with Pin & Hanger Connection

Sometimes, both types of superstructure, rolled steel beams and fabricated steel girders can be used on the same bridge (see Figure 10.1.10). The shorter approach spans are rolled beams while the longer main span utilizes fabricated girders.



Figure 10.1.10 Combination Rolled Beams and Fabricated Girders

Haunched Girder Design In continuous girder designs, additional girder strength is required in negative moment regions. This is accomplished through a method called haunching. Haunching is the increasing of the web depth for a specified portion of the girder. The regions above intermediate supports (i.e. piers and bents) have negative moments larger than the adjacent positive moments. Typically, the girder depth used at the positive moment regions is not sufficient enough to resist these moments, so the web depth is increased. (See Topic 5.1, Bridge Mechanics) However, instead of increasing the depth for the full length of the girder, the girder is haunched at the intermediate supports.

Three methods have been used to haunch girders.

To haunch a riveted plate girder, a larger web plate size is used in the region required.

To haunch a rolled beam, the bottom flange is separated from the web and an insert plate of the required depth is welded in place (see Figure 10.1.11).

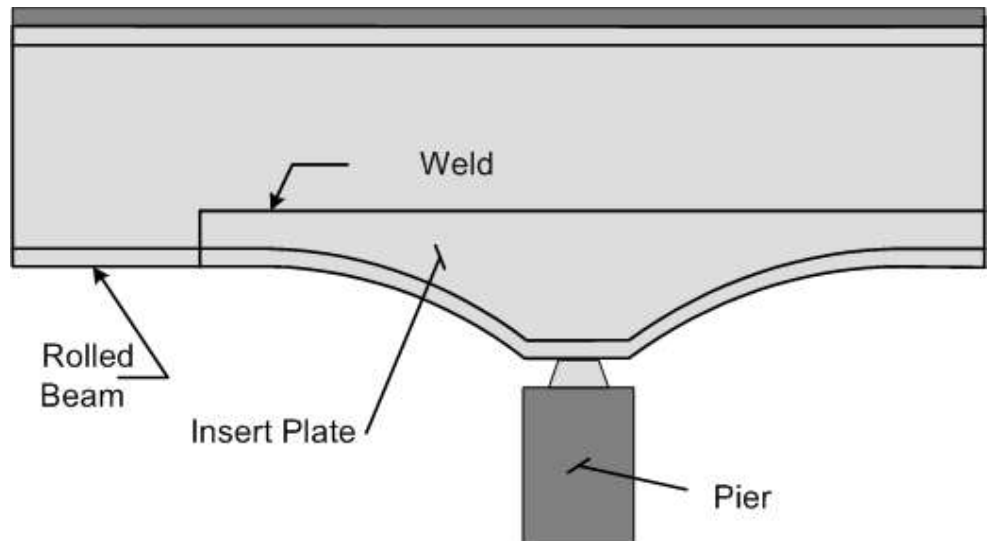

Figure 10.1.11 Web Insert Plate for Multi-beam

A fabricated variable depth girder is the method used today (see Figure 10.1.12). The web plate is simply fabricated to the required depth. The top and bottom flange plates are then welded to the web plate.

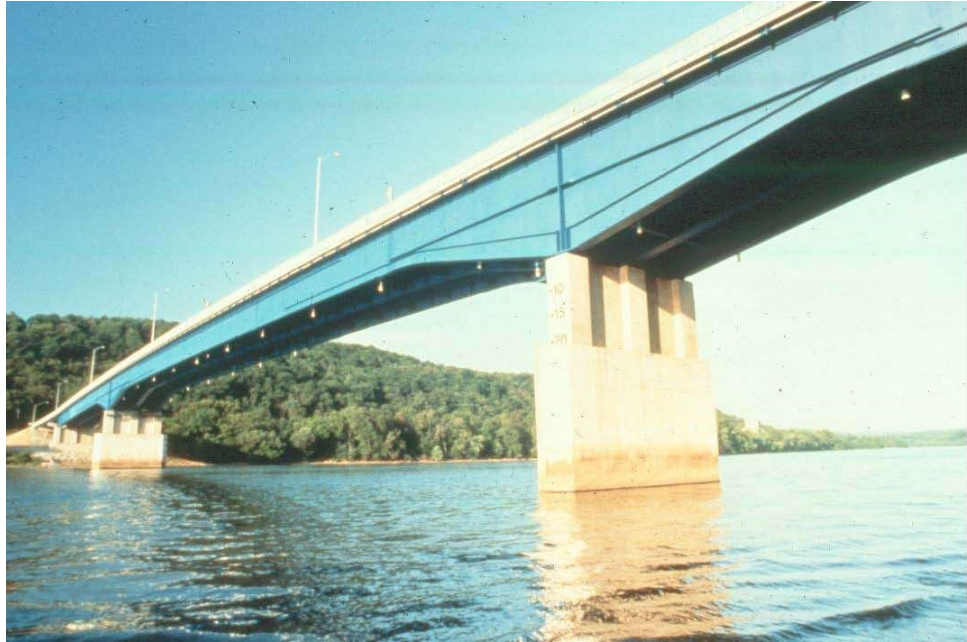

Figure 10.1.12 Fabricated Variable Depth Girder Bridge

Function of Stiffeners

As fabricated girders become longer, the depth of the web plate increases, and it becomes susceptible to web buckling (i.e., failure of the web due to compressive or shear stresses). Bridge designers prevent this from occurring by increasing the web thickness or by reinforcing the web with steel stiffener plates. Stiffeners can be either transverse (vertical) or longitudinal (horizontal). They can be placed on one or both sides of the web. The stiffeners limit the unsupported length of the web, which results in increased stability of the girder.

Primary and Secondary Members

Primary members are designed to resist primary live loads from trucks and dead loads.

Secondary members do not resist primary live loads.

The primary members of a rolled multi-beam bridge are the rolled beams, and the secondary members are the diaphragms (see Figure 10.1.13). Intermediate and end diaphragms are provided to stabilize the beams during construction and to help distribute the live load more evenly to the rolled beams. Diaphragms may or may not be present on multi-beam bridges.

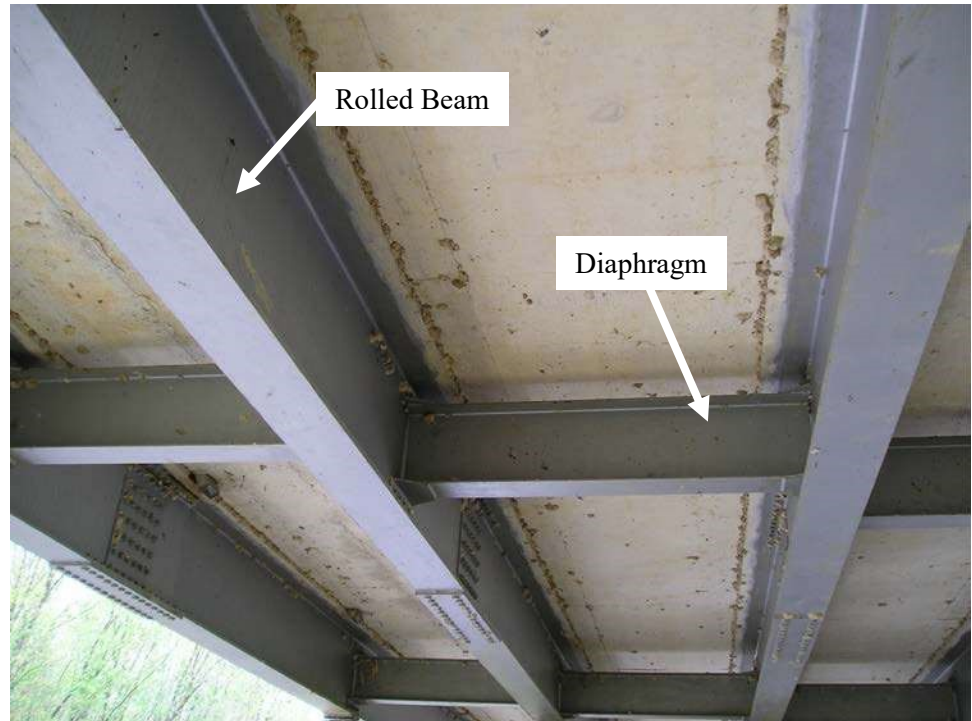

Figure 10.1.13 Rolled Beam (Primary Member) with Diaphragm (Secondary Member)

The primary members of a fabricated multi-girder bridge are the fabricated girders, as well as the diaphragms on a curved bridge. In the case of a curved structure, the diaphragms are designed to withstand the torsional loading attributed to curved structures and therefore, are also considered primary members (see Figure 10.1.14).

On straight multi-girder bridges, diaphragms are considered secondary members. Similar to rolled beam bridges, diaphragms are provided to stabilize the girders during construction and to help distribute secondary live load (see Figure 10.1.15). Diaphragms can be rolled shapes (e.g., I-beams and channels) or they can be cross-frames constructed from angles, tee shapes, and plates. They are usually attached to transverse web stiffeners which are normally referred to as connection plates. On older bridges, secondary members also include lateral bracing. Current design specifications discourage the use of lateral bracing. This is due to connections for lateral bracing being fatigue-prone.

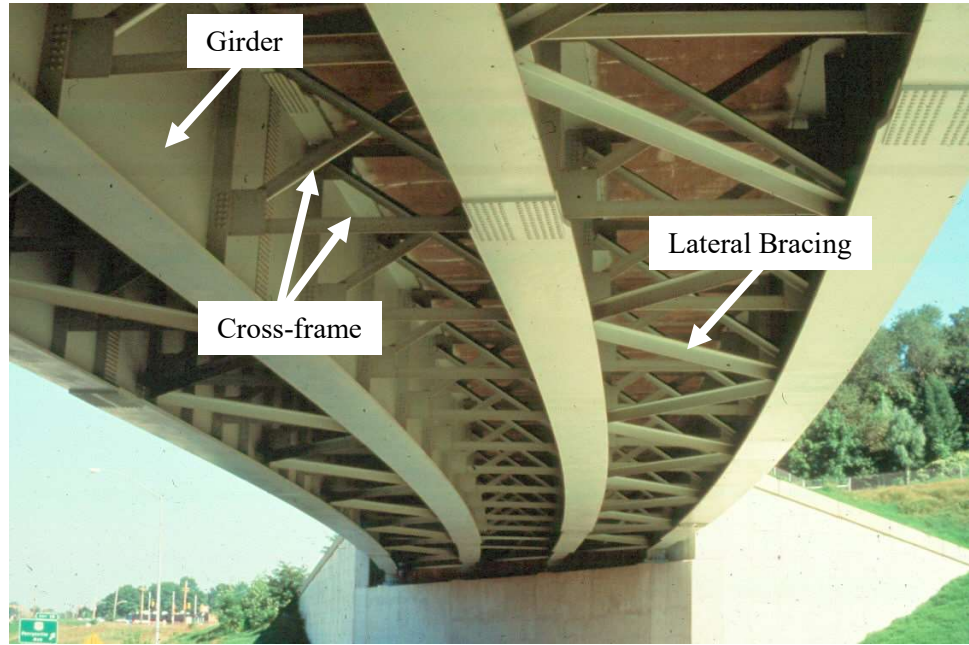

Figure 10.1.14 Curved Multi-Girder Bridge



Figure 10.1.15 Straight Multi-Girder Bridge

Fracture Critical Areas

Both rolled multi-beam bridges and steel multi-girder bridges consist of a minimum of three beams or girders and have load path redundancy. Since load path redundancy is achieved, these bridge types do not contain any fracture critical members.

10.1.3

Overview of Common Deficiencies

Common deficiencies that occur on steel multi-beam and fabricated multi-girder bridges are:

- Corrosion
- Fatigue cracking
- Overloads
- Collision damage
- Heat damage
- Coating failures

See Topic 6.3 for a detailed presentation of the properties of steel, types and causes of steel deterioration, and the examination of steel. Refer to Topic 6.4 for Fatigue and Fracture in Steel Bridges.

10.1.4

Inspection Methods and Locations

Inspection methods to determine steel deterioration are described in detail in Topic 6.3.7.

Methods

Visual

The inspection of steel bridge members for defects is primarily a visual activity.

Most defects in steel bridges are first detected by visual inspection. In order for this to occur, a hands-on inspection, or inspection where the inspector is close enough to touch the area being inspected, is typically required. More exact visual observations can also be employed using a magnifying unit after cleaning the suspect area.

Physical

Removal of paint can be done using a wire brush, grinding, or sand blasting, depending on the size and location of the suspected defect. Exercise care when cleaning suspected defects that are cracks. When cleaning steel surfaces, avoid any type of cleaning process that would tend to close discontinuities, such as blasting. The use of degreasing spray before and after removal of the paint may help in revealing the defect.

When section loss occurs, use a wire brush, grinder or hammer to remove loose or flaked steel. After the flaked steel is removed, measure the remaining section and compare it to a similar section with no section loss.

The usual and most reliable sign of fatigue cracks is the oxide or rust stains that develop after the paint film has cracked. Experience has shown that cracks have generally propagated to a depth between one-fourth and one-half the plate thickness before the paint film is broken, permitting the oxide to form. This occurs because the paint is more flexible than the underlying steel.

Smaller cracks are not likely to be detected visually unless the paint, mill scale, and dirt are removed by carefully cleaning the suspect area. If the confirmation of a possible crack is to be conducted by another person, it is advisable not to disturb the suspected crack area so that re-examination of the actual conditions can be made.

Once the presence of a crack has been verified, examine all other similar locations and details.

Advanced Inspection Methods

Several advanced methods are available for steel inspection. Nondestructive methods, described in Topic 15.3.2, include:

- Acoustic emissions testing
- Corrosion sensors
- Smart coatings
- Dye penetrant
- Magnetic particle
- Radiographic testing
- Computed tomography
- Robotic inspection
- Ultrasonic testing
- Eddy current
- Electrochemical fatigue sensor (EFS)
- Magnetic flux leakage
- Laser vibrometer

Other methods, described in Topic 15.3.3, include:

- Brinell hardness test
- Charpy impact test
- Chemical analysis
- Tensile strength test

Locations

Bearing Areas

Examine the web areas over the supports for cracks, section loss or buckling. If bearing stiffeners, jacking stiffeners and diaphragms are present at the supports inspect them for cracks, section loss and buckling also.

Examine the bearings at each support for corrosion. Check the alignment of each bearing and note any movement. Report any build up of debris surrounding the bearings that may limit the bearing from functioning properly. Check for any bearings that are frozen due to heavy corrosion. See Topic 11.1 for a detailed description on the inspection of bridge bearings.

Shear Zones

Examine the web areas near the supports for any section loss or buckling (see Figure 10.1.16). Shear stresses are greatest near the supports. Therefore, the condition of the web is more critical near the supports than at mid-span. Also investigate the web for buckling due to overloads. If girders have been haunched by the use of insert plates, check the weld between the web and the insert plate.



Figure 10.1.16 Corroded Shear Zone on a Rolled Multi-beam Bridge

Flexure Zones

The flexure zone of each beam/girder includes the entire length between the supports (see Figures 10.1.17 and 10.1.18). Investigate the tension and compression flanges for corrosion, loss of section, cracks, dings, and gouges. Check the flanges in high stress areas for bending or flexure-related damage. Examine the compression flange for local buckling and, although it is uncommon, for elongation or fracture of the tension flange. On continuous spans, the beam/girder over the intermediate supports has high flexural stresses due to

negative moment (see Figures 10.1.19 and 10.1.20). If welded cover plates are present, check carefully at the ends of the cover plates for cracks due to fatigue.

P. M. - Positive Moment



Figure 10.1.17 Flexural Zone on a Multi-Span Simple Span Rolled Multi-Beam Bridge

P. M. - Positive Moment
N.M. - Negative Moment

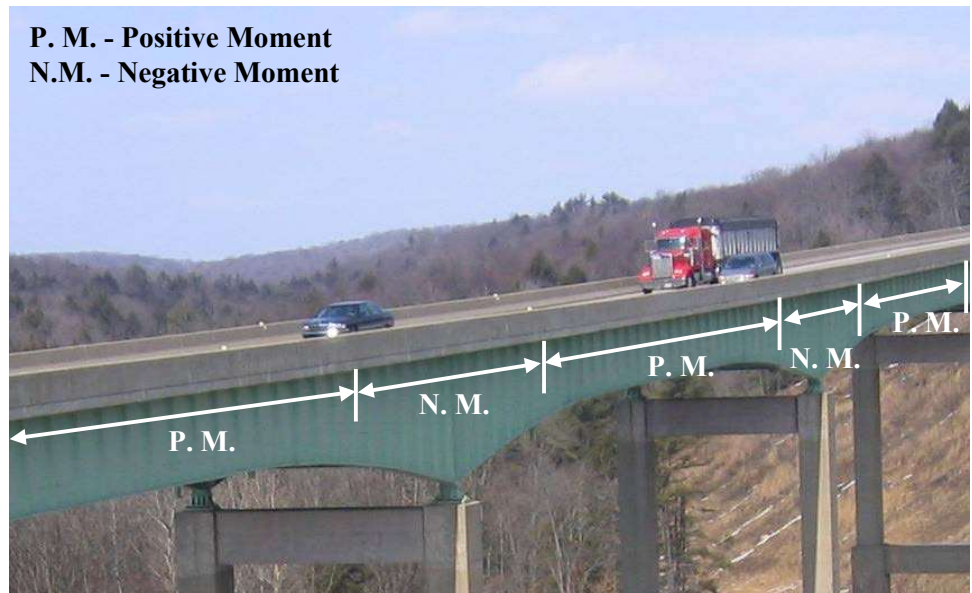

Figure 10.1.18 Flexural Zone on a Fabricated Continuous Span Multi-Girder Bridge



Figure 10.1.19 Negative Moment Region on a Continuous Span Rolled Multi-Beam Bridge

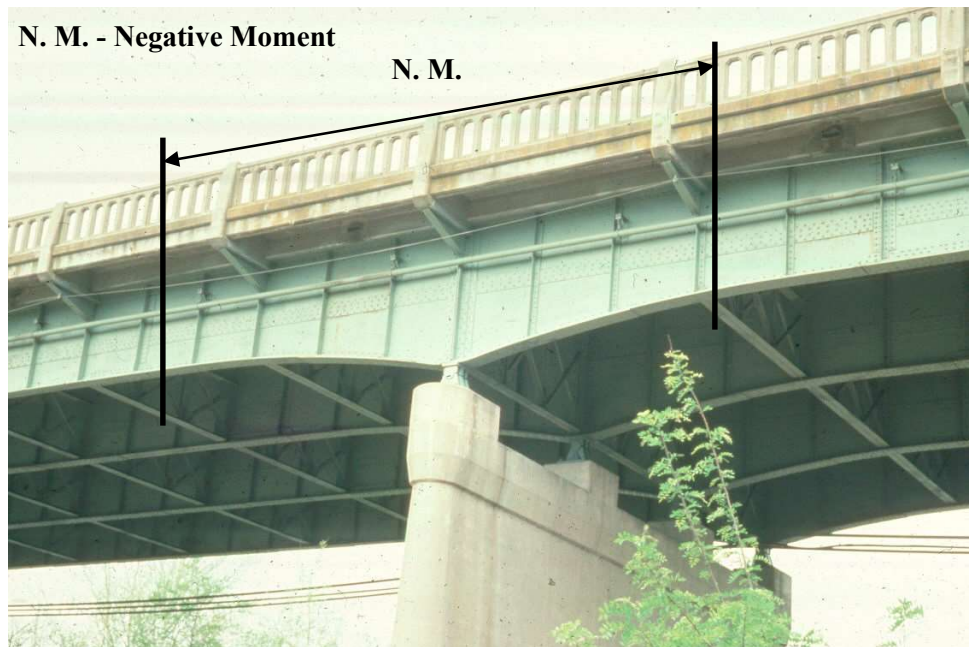

Figure 10.1.20 Negative Moment Region on a Continuous Span Fabricated Multi-Girder Bridge

Secondary Members

Examine the diaphragm and bracing connections for loose fasteners or cracked welds (see Figures 10.1.21 and 10.1.22). This problem is most common on skewed bridges, and it has also been observed on bridges with a high frequency of combination truck loads. Check horizontal connection plates, which can trap debris and moisture and are susceptible to a high degree of corrosion and deterioration. Check for distorted members. Distorted secondary members may be an indication the primary members may be overstressed or the substructure may be experiencing differential settlement.



Figure 10.1.21 End Diaphragm



Figure 10.1.22 Intermediate Diaphragm

Areas Exposed to Drainage

Check horizontal surfaces that can trap debris and moisture which are susceptible to a high degree of corrosion and deterioration. Areas that trap water and debris can result in active corrosion cells and excessive loss in section. This can result in notches susceptible to fatigue or perforation and loss of section.

On multi-beam and fabricated multi-girder bridges check:

- Areas exposed to drainage runoff
- Along the bottom flanges
- Pockets created by diaphragm connections
- Lateral bracing gusset plates

Areas Exposed to Traffic

Check underneath the bridge for collision damage to the main girders and bracing if the bridge crosses over a highway, railway, or navigable channel. Document any cracks, section loss, or distortion found (see Figures 10.1.23 and 10.1.24).



Figure 10.1.23 Collision Damage on a Rolled Multi-Beam Bridge



Figure 10.1.24 Collision Damage on a Fabricated Multi-Girder Bridge

Problematic Details

Problematic details checked for deficiencies and deterioration include:

- Triaxial constraint
- Intersecting welds
- Cover plates
- Cantilevered suspended spans
- Insert plates
- Field welds: patch and splice plates
- Intermittent welds
- Out-of-plane bending
- Pin-and-hanger assemblies
- Back-up bars
- Mechanical fasteners and tack welds

Note that out-of-plane bending may occur at the following areas, which are presented further in Topic 6.4.8:

- Girder web connections for diaphragms and floorbeams, including connections plates at the top flange, connection plates at the bottom flange, and connection plates at the bottom flange for skewed bridges
- Staggered floorbeams or lateral gusset plate locations (for skewed bridges)
- Lateral bracing gussets and diaphragm connection plates

In addition to common problematic details, beams also utilize the following:

- Stiffeners (transverse and longitudinal)
- Groove welded butt splices
- Lateral bracing gusset plates
- Web-to-flange welds
- Misc. connections (railing and utilities)
- Flanges cut short
- Coped flanges
- Blocked flanges

See Topic 6.4.8 for additional information on problematic details.

Fracture Critical Members

Both rolled multi-beam superstructures and fabricated multi-girder superstructures have load path redundancy, and therefore have no fracture critical members.

10.1.5

Evaluation

State and Federal rating guideline systems have been developed to aid in the inspection of steel superstructures. The two major rating guideline systems currently in use are the FHWA's *Recording and Coding Guide for the Structural Inventory and Appraisal of the Nation's Bridges* used for the National Bridge Inventory (NBI) component condition rating method and the AASHTO *Guide Manual for Bridge Element Inspection* for element level condition state assessment.

NBI Component Condition Rating Guidelines

Using NBI component condition rating guidelines, a one-digit code on the Federal Structure Inventory and Appraisal (SI&A) sheet indicates the condition of the superstructure. Component condition rating codes range from 9 to 0 where 9 is the best rating possible. See Topic 4.2 (Item 59) for additional details about NBI component condition rating guidelines.

Consider previous inspection data along with current inspection findings to determine the correct component condition rating.

Element Level Condition State Assessment

In an element level condition state assessment of a steel girder bridge, possible AASHTO National Bridge Elements (NBEs) and Bridge Management Elements (BMEs) are:

NBE No.

Description

Superstructure

107

Steel Girder/Beam

161

Pin, Pin-and-Hanger Assembly, or both

BME No.

Description

Wearing Surfaces and Protection Systems

515

Steel Protective Coating

The unit quantity for the girder/beam is feet. The total length is distributed among the four available condition states depending on the extent and severity of the deficiency. The unit quantity for the pin-and-hanger assembly (if applicable) is each, with each pin-and-hanger element placed in one of the four available condition states depending on the extent and severity of the deficiency. The unit quantity for protective coating is square feet, and the total area is distributed among the four available condition states depending on the extent and severity of the deficiency. The sum of all condition states equals the total quantity of the National Bridge Element or Bridge Management Element. Condition State 1 is the best possible rating. See the *AASHTO Guide Manual for Bridge Element Inspection* for condition state descriptions.

The following Defect Flags are applicable in the evaluation of steel multi-beam and multi-girder superstructures:

CHAPTER 10: Inspection and Evaluation of Steel Superstructures
TOPIC 10.1: Rolled Steel Multi-Beams and Fabricated Steel Multi-Girders

<u>Defect Flag No.</u>	<u>Description</u>
356	Steel Cracking/Fatigue
357	Pack Rust
362	Superstructure Traffic Impact (load capacity)
363	Steel Section Loss
364	Steel out-of-plane (Compression Member)

See the AASHTO *Guide Manual for Bridge Element Inspection* for the application of Defect Flags.

CHAPTER 10: Inspection and Evaluation of Steel Superstructures
TOPIC 10.1: Rolled Steel Multi-Beams and Fabricated Steel Multi-Girders

This page intentionally left blank.

Table of Contents

Chapter 10 Inspection and Evaluation of Steel Superstructures

10.2	Steel Two-Girder Systems	10.2.1
10.2.1	Introduction.....	10.2.1
10.2.2	Design Characteristics.....	10.2.3
	Floor System Arrangement.....	10.2.3
	Primary and Secondary Members	10.2.5
	Fracture Critical Areas	10.2.6
	Girders	10.2.6
	Floorbeams.....	10.2.7
10.2.3	Overview of Common Deficiencies.....	10.2.8
10.2.4	Inspection Methods and Locations	10.2.8
	Methods	10.2.8
	Visual	10.2.8
	Physical.....	10.2.8
	Advanced Inspection Methods.....	10.2.9
	Locations	10.2.9
	Bearing Areas.....	10.2.9
	Shear Zones.....	10.2.10
	Flexure Zones.....	10.2.11
	Secondary Members.....	10.2.12
	Areas Exposed to Drainage.....	10.2.13
	Areas Exposed to Traffic	10.2.13
	Problematic Details.....	10.2.15
	Fracture Critical Members	10.2.16
10.2.5	Evaluation	10.2.16
	NBI Component Condition Rating Guidelines.....	10.2.16
	Element Level Condition State Assessment.....	10.2.16

This page is intentionally left blank.

Topic 10.2 Steel Two-Girder Systems

10.2.1

Introduction

The steel two-girder bridge, like the fabricated multi-girder bridge, can use either riveted or welded construction. The difference is that it has only two girders. Two-girder bridges can also have features similar to those of fabricated multi-girder bridges, such as web insert plates, transverse web stiffeners, and longitudinal web stiffeners (see Figure 10.2.1).

However, unlike the fabricated multi-girder bridge, the two-girder bridge has a floor system of smaller longitudinal stringers and transverse floorbeams. The floor system supports the deck while the girders support the floor system.

Two-girder bridges are typically straight bridges arranged in simple and/or continuous span configurations, but may be curved structures. Pin-and-hanger assemblies may be associated with two-girder bridges. Two-girder bridges are classified as either deck girder or through girder systems.

In a deck girder system, the deck is supported by the floor system and top flanges of the two girders (see Figure 10.2.1). In a through girder system, the deck is supported by the floor system between the two girders and the two girders extend above the deck. (see Figure 10.2.2).



Figure 10.2.1 General View of a Deck Girder Bridge

While few through girders are constructed today, they were commonly used prior to the early 1950's. Since many through girder bridges were constructed in the 1940's and 1950's, they are commonly riveted. Their most common use was where vertical underclearance was a concern, such as over railroads (see Figure 10.2.3).



Figure 10.2.2 Through Girder Bridge



Figure 10.2.3 Through Girder Bridge with Limited Underclearance

A rare type of through girder has three or more girders, with the main girders actually separating the traffic lanes (see Figure 10.2.4). These structures are most likely converted railroad or trolley bridges.



Figure 10.2.4 Through Girder Bridge with Three Girders

10.2.2

Design Characteristics

Floor System Arrangement

Floor systems are similar in deck girder and through girder systems.

The floor system supports the deck. There are two types of floor systems found on two-girder bridges:

- Girder-floorbeam system
- Girder-floorbeam-stringer system

The girder-floorbeam (GF) system consists of floorbeams connected to the main girders. The floorbeams are considerably smaller than the girders and are perpendicular to traffic. The deck is supported by the floorbeams, which in turn transmit the loads to the main girders. The floorbeams can be either rolled beams, fabricated girders, or fabricated cross frames (see Figure 10.2.5).



Figure 10.2.5 Two-Girder Bridge with Girder-Floorbeam System

The girder-floorbeam-stringer (GFS) system consists of floorbeams connected to the main girders, and longitudinal stringers, parallel to the main girders, connected to the floorbeams (see Figure 10.2.6). The stringers may either connect to the web of the floorbeams or be stacked on top of the floorbeams, in which case they may be continuous or simply supported stringers. Stringers are usually rolled beams and are considerably smaller than the floorbeams. It is also possible to find floorbeams that are stacked on top of the main girders, and the floorbeams may extend or overhang from the girders (see Figure 10.2.7). This stack configuration reduces problematic details that may lead to fatigue cracking.



Figure 10.2.6 Two-Girder Bridge with Girder-Floorbeam-Stringer System



Figure 10.2.7 Two-Girder Bridge GFS System with Stacked Floorbeam and Stringers

Primary and Secondary Members

The primary members of a two-girder bridge are the girders, floorbeams, and stringers, if present. The secondary members are diaphragms and the lateral bracing members, if present. These secondary members usually consist of channels, angles or tee shapes placed diagonally in horizontal planes between the two main girders. The lateral bracing is generally in the plane of the bottom flange. Lateral bracing serves to minimize any differential longitudinal movement between the two girders (see Figure 10.2.8). Not all two-girder bridges will have a lateral bracing system. Diaphragms, if present, are usually placed between stringers.

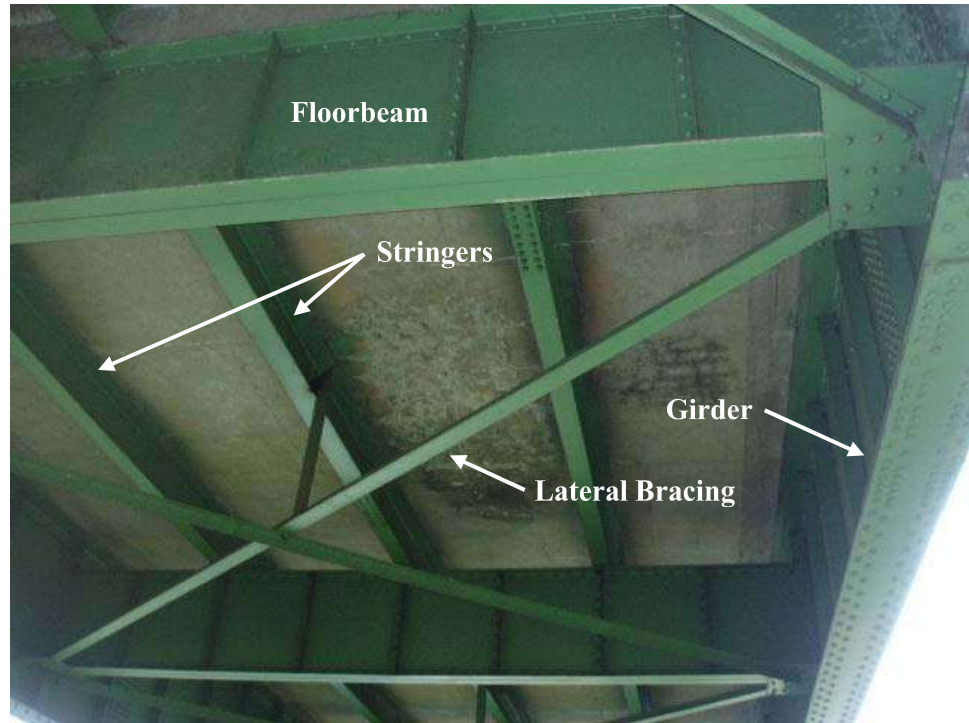

Figure 10.2.8 Underside View of Deck Girder Bridge with Lateral Bracing System

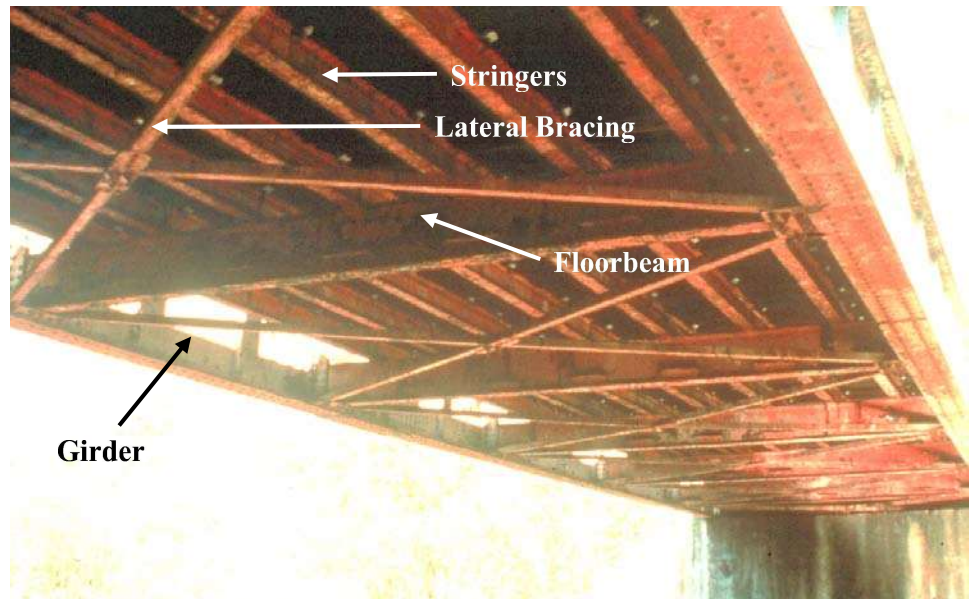

Figure 10.2.9 Underside View of Through Girder Bridge with Lateral Bracing

Fracture Critical Areas Girders

Two-girder bridges (deck girder and through girder) do not have load path redundancy. Since the girders are constructed of steel, are in tension, and would result in a partial or total bridge collapse if the member fails, they are considered fracture critical. Both deck and through girder bridges are therefore classified as fracture critical bridge types.

Pin-and-hanger assemblies in two-girder bridges are fracture critical members (see Figure 10.2.10). Failure of one pin or one hanger will cause collapse of the suspended span since there is no alternate load path (e.g., Mianus River Bridge). Pins are considered “frozen” when corrosion restricts rotation. The pins and hangers experience additional bearing, torsion, bending and shear stresses when the pin-and-hanger assembly is frozen. This is a critical situation when it occurs on a (load path) nonredundant two-girder bridge.

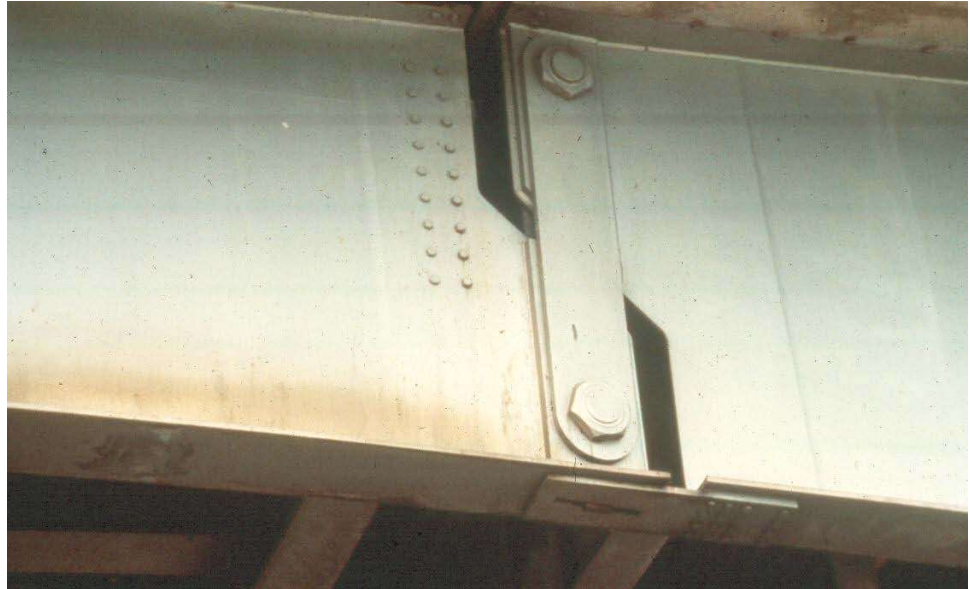

Figure 10.2.10 Two-Girder Bridge with Pin-and-Hanger Assembly

In the interest of conservatism, AASHTO chooses to neglect structural and internal redundancy and classify all two-girder bridges as (load path) nonredundant.

Floorbeams

A floorbeam may be fracture critical if it satisfies one or more of the following conditions:

- Flexible or hinged connection to support at the girder/floorbeam connection
- Floorbeam spacing greater than 14'-0"
- No stringers supporting the deck
- Stringers are configured as simple beams

Some states consider any floorbeam to be fracture critical even if none of the above conditions are met.

A three-dimensional finite element structural analysis to determine fracture criticality may be performed to determine the exact consequences to the bridge if a floorbeam or floorbeam connection fails.

10.2.3

Overview of Common Deficiencies

Common deficiencies that occur on steel two-girder and steel through girder bridges include:

- Corrosion
- Fatigue cracking
- Overloads
- Collision damage
- Heat damage
- Coating failures

See Topic 6.3.5 for a detailed presentation of the properties of steel, types and causes of steel deterioration, and the examination of steel. Refer to Topic 6.4 for Fatigue and Fracture in Steel Bridges.

10.2.4

Inspection Methods and Locations

Inspection methods to determine other causes of steel deterioration are detailed in Topic 6.3.7.

Methods

Visual

The inspection of steel bridge members for deficiencies is primarily a visual activity.

Most deficiencies in steel bridges are first detected by visual inspection. In order for this to occur, a hands-on inspection, or inspection where the inspector is close enough to touch the area being inspected, is typically required. More exact visual observations can also be employed using a magnifying unit after cleaning the suspect area. All fracture critical members are required to be inspected within arm's length during each inspection.

Physical

Removal of paint can be done using a wire brush, grinding, or sand blasting, depending on the size of the suspected deficiency. Exercise care when cleaning suspected areas that are cracked. When cleaning steel surfaces, avoid any type of cleaning process that would tend to close discontinuities, such as blasting. The use of degreasing spray before and after removal of the paint may help in revealing the deficiency.

When section loss occurs, use a wire brush, grinder or hammer to remove loose or flaked steel. After the flaked steel is removed, measure the remaining section and compare it to a similar section with no section loss.

The usual and most reliable sign of fatigue cracks is the oxide or rust stains that develop after the paint film has cracked. Experience has shown that cracks have generally propagated to a depth between one-fourth and one-half the plate thickness before the paint film is broken, permitting the oxide to form. This occurs because the paint is more flexible than the underlying steel.

Smaller cracks are not likely to be detected visually unless the paint, mill scale, and dirt are removed by carefully cleaning the suspect area. If the confirmation of a possible crack is to be conducted by another person, it is advisable not to disturb the suspected crack area so that re-examination of the actual conditions can be made.

Once the presence of a crack has been verified, examine all other similar locations and details on the bridge.

Advanced Inspection Methods

Several advanced methods are available for steel inspection. Nondestructive methods, described in Topic 15.3.2, include:

- Acoustic emissions testing
- Corrosion sensors
- Smart coatings
- Dye penetrant
- Magnetic particle
- Radiographic testing
- Computed tomography
- Robotic inspection
- Ultrasonic testing
- Eddy current
- Electrochemical fatigue sensor (EFS)

Other methods, described in Topic 15.3.3, include:

- Brinell hardness test
- Charpy impact test
- Chemical analysis
- Tensile strength test

Locations

Bearing Areas

Examine the web of girders, floorbeams and stringers areas over the supports for cracks, section loss and buckling. If bearing stiffeners, jacking stiffeners and diaphragms are present at the supports inspect them for cracks, section loss and buckling also.

Examine the bearings at each support for corrosion. Check the alignment of each bearing and note any movement. Report any build up of debris surrounding the bearings that may limit the bearing from functioning properly. Check for any bearings that are frozen due to heavy corrosion. See Topic 11.1 for a detailed presentation on the inspection of bridge bearings.

Shear Zones

Examine the web areas of the girders, floorbeams, and stringers near their supports for section loss or buckling (see Figures 10.2.11 and 10.2.12). This is a critical area, especially if the web is coped or the flange is blocked.



Figure 10.2.11 Shear Zone on a Deck Girder Bridge



Figure 10.2.12 Web Area Near Support on a Through Girder Bridge

Flexure Zones

The flexure zone of each girder includes the entire length between the supports (see Figures 10.2.13 and 10.2.15). Investigate the tension and compression flanges for corrosion, loss of section, cracks, dings, and gouges. Check the flanges in high stress areas for bending or flexure-related damage. Examine the compression flange for local buckling and, although it is uncommon, for elongation or fracture of the tension flange. On continuous spans, the beams over the intermediate supports have high flexural stresses due to negative moment. Check flange splice welds and longitudinal stiffener splice welds in tension areas (see Figure 10.2.14).

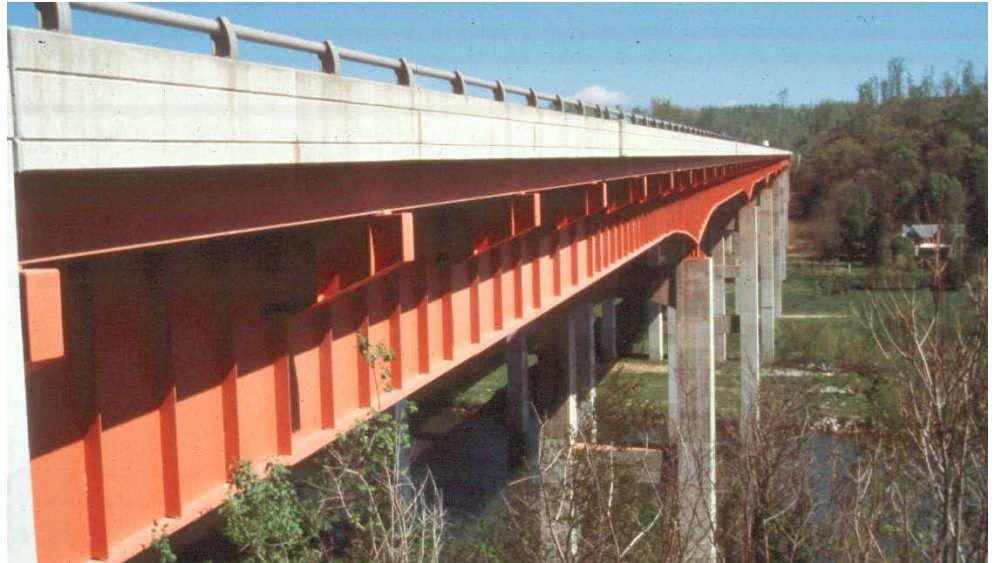

Figure 10.2.13 Flexural Zone on a Two-Girder Bridge

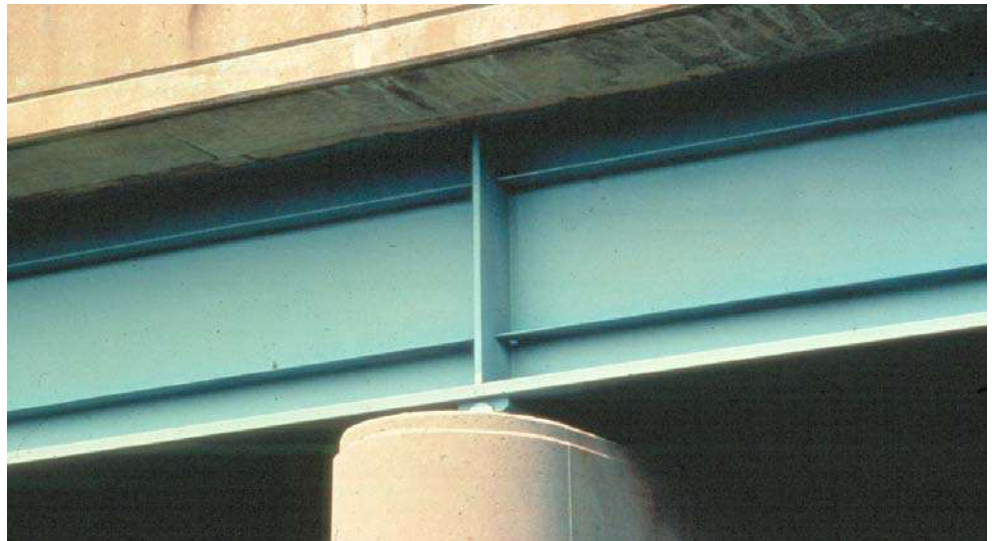

Figure 10.2.14 Longitudinal Stiffener in Tension Zone on a Two-Girder Bridge

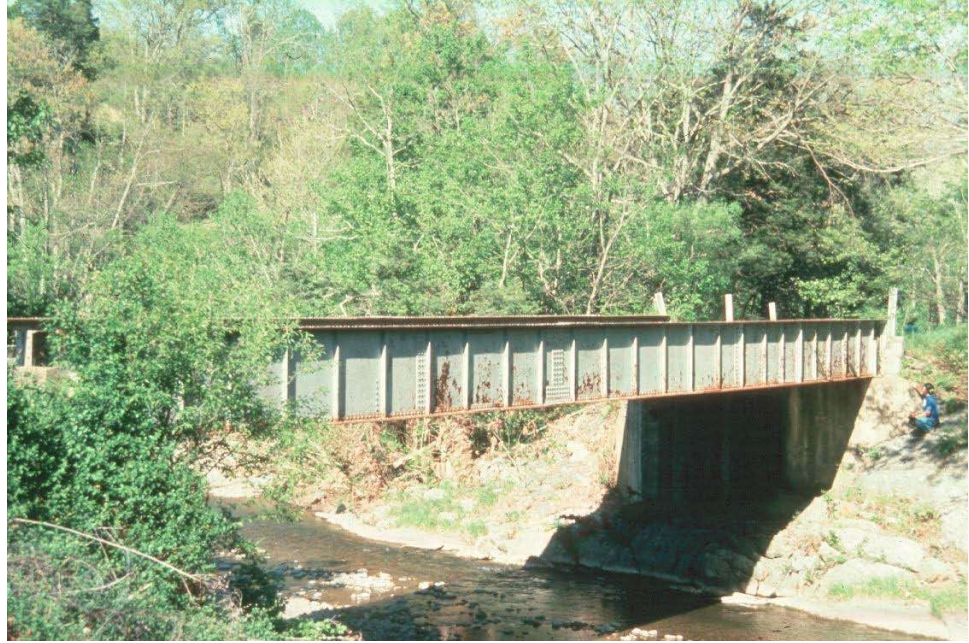

Figure 10.2.15 Flexural Zone on a Through Girder Bridge

Secondary Members

Examine the diaphragms, if present, and the connection areas of the lateral bracing for cracked welds, fatigue cracks, and loose fasteners. Inspect the bracing members for any distortion or corrosion (see Figures 10.2.16 and 10.2.17). Distorted or cracked secondary members may be an indication the primary members are overstressed or the substructure may be experiencing differential settlement.



Figure 10.2.16 Lateral Bracing Connection on a Deck Girder Bridge

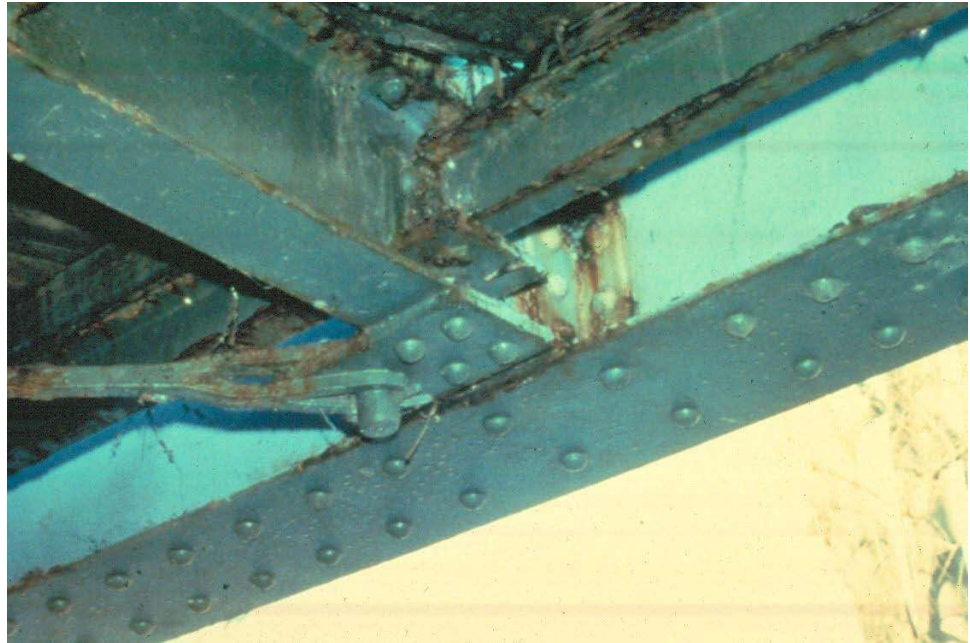

Figure 10.2.17 Lateral Bracing Connection on a Through Girder Bridge

Areas Exposed to Drainage

Check horizontal surfaces that can trap debris and moisture and are susceptible to a high degree of corrosion and deterioration. Areas that trap water and debris can result in active corrosion cells and excessive loss in section. This can result in notches susceptible to fatigue or perforation and loss of section.

On two-girder bridges check:

- Along the bottom flanges of the girders
- Pockets created by girder-floorbeams and floorbeam-stringer connections
- Lateral bracing gusset plates
- Areas exposed to drainage runoff
- Along the girder webs at the curb line (through girder system)

Areas Exposed to Traffic

Check underneath the bridge for collision damage to the main girders and bracing if the bridge crosses over a highway, railway, or navigable channel. Document any cracks, section loss, or distortion found (see Figures 10.2.18 and 10.2.19). On a through girder bridge, investigate the main girders along the curb lines and at the ends for collision damage.

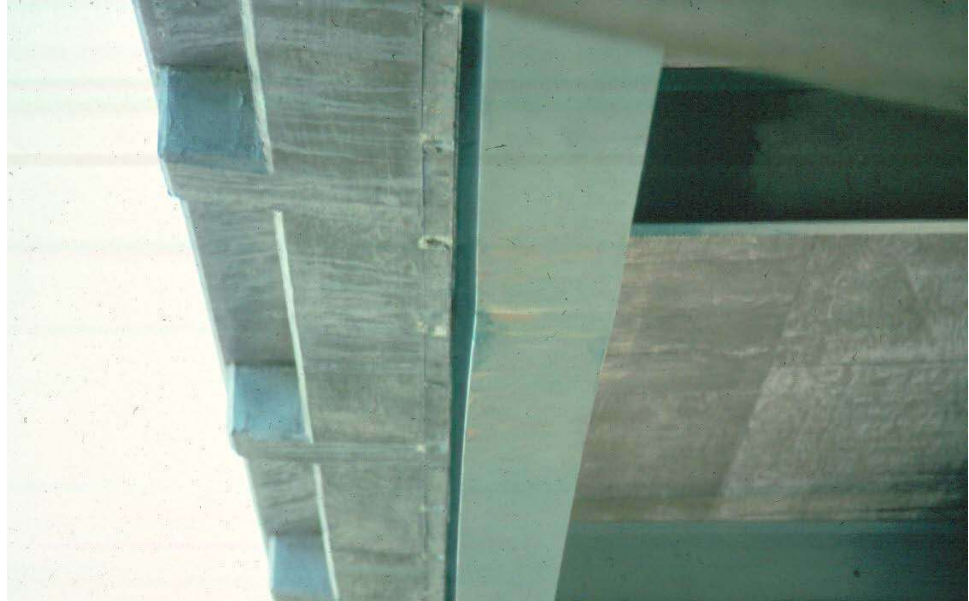

Figure 10.2.18 Collision Damage to a Deck Girder Bridge



Figure 10.2.19 Collision Damage to a Through Girder Bridge

Problematic Details

Problematic details checked for deficiencies and deterioration include:

- Triaxial constraint
- Intersecting welds
- Cover plates
- Cantilevered suspended spans
- Insert plates
- Field welds: patch and splice plates
- Intermittent welds
- Out-of-plane bending
- Pin-and-hanger assemblies
- Back-up bars
- Mechanical fasteners and tack welds

Note that out-of-plane bending may occur at the following areas, which are presented further in Topic 6.4.8:

- Girder web connections for diaphragms and floorbeams, including connections plates at the top flange, connection plates at the bottom flange, and connection plates at the bottom flange for skewed bridges
- Lateral bracing gussets and diaphragm connection plates
- Diaphragm connections to gusset plates
- Cantilevered floorbeams

In addition to the common problematic details, girders also utilize the following:

- Stiffeners (transverse/longitudinal)
- Groove welded butt splices
- Lateral bracing gusset plates
- Web-to-flange welds
- Miscellaneous connections (railing/utilities)

See Topic 6.4.8 for additional information on problematic details.

Fracture Critical Members

Since two-girder bridges have no load path redundancy and are fracture critical, it is important to inspect the main girders thoroughly. Floorbeams may also be fracture critical if they meet the requirements specified in Topic 10.2.2. Bridge specific written inspection procedures should be developed for each bridge with fracture critical members. Document and measure any defects such as cracks, section loss and out-of plane distortions. Review bridge specific inspection procedures and all previous reports before performing the inspection to note any areas of particular concern. Check all reported deficiencies to ensure no further development has occurred.

10.2.5

Evaluation

State and Federal rating guideline systems have been developed to aid in the inspection of steel superstructures. The two major rating guideline systems currently in use are the FHWA's *Recording and Coding Guide for the Structural Inventory and Appraisal of the Nation's Bridges* used for the National Bridge Inventory (NBI) component condition rating method and the AASHTO *Guide Manual for Bridge Element Inspection* for element level condition state assessment.

NBI Component Condition Rating Guidelines

Using NBI component condition rating guidelines, a one-digit code on the Federal Structure Inventory and Appraisal (SI&A) sheet indicates the condition of the superstructure. Component condition rating codes range from 9 to 0 where 9 is the best rating possible. See Topic 4.2 (Item 59) for additional details about NBI component condition rating guidelines.

Consider previous inspection data along with current inspection findings to determine the correct component condition rating.

Element Level Condition State Assessment

In an element level condition state assessment of a steel two-girder system, possible AASHTO National Bridge Elements (NBEs) and Bridge Management Elements (BMEs) are:

NBE No.

Description

Superstructure

107	Steel Girder/Beam
113	Steel Stringer
152	Steel Floorbeam
161	Pin, Pin-and-Hanger Assembly, or both

BME No.

Description

Wearing Surfaces and Protection Systems

515	Steel Protective Coating
-----	--------------------------

The unit quantity for the girder, stringer (if applicable), and floorbeam is feet. The total length is distributed among the four available condition states depending on the extent and severity of the deficiency. The unit quantity for the pin-and-hanger assembly (if applicable) is each, with each pin-and-hanger element placed in one of the four available condition states depending on the extent and severity of the deficiency. The unit quantity for protective coating is square feet, and the total area is distributed among the four available condition states depending on the extent and severity of the deficiency. The sum of all condition states equals the total quantity of the National Bridge Element or Bridge Management Element. Condition State 1 is the best possible rating. See the *AASHTO Guide Manual for Bridge Element Inspection* for condition state descriptions. For pin-and-hanger assemblies, see Topic 10.7.

The following Defect Flags are applicable in the evaluation of the steel two-girder systems:

<u>Defect Flag No.</u>	<u>Description</u>
356	Steel Cracking/Fatigue
357	Pack Rust
362	Superstructure Traffic Impact (load capacity)
363	Steel Section Loss
364	Steel out-of-plane (Compression Member)

See the *AASHTO Guide Manual for Bridge Element Inspection* for the application of Defect Flags.

This page intentionally left blank.

Table of Contents

Chapter 10 Inspection and Evaluation of Steel Superstructures

10.3	Steel Box Beams and Girders	10.3.1
10.3.1	Introduction.....	10.3.1
10.3.2	Design Characteristics.....	10.3.2
	Configuration.....	10.3.2
	Primary and Secondary Members	10.3.3
	Function of an Internal Stiffener	10.3.3
	Fracture Critical Areas	10.3.5
	Deck Interaction	10.3.5
10.3.3	Overview of Common Deficiencies.....	10.3.6
10.3.4	Inspection Methods and Locations	10.3.6
	Methods	10.3.6
	Visual	10.3.6
	Physical	10.3.6
	Advanced Inspection Methods.....	10.3.7
	Locations	10.3.7
	Bearing Areas.....	10.3.7
	Shear Zones.....	10.3.8
	Flexure Zones.....	10.3.9
	Secondary Members.....	10.3.9
	Areas Exposed to Drainage.....	10.3.9
	Areas Exposed to Traffic	10.3.9
	Problematic Details.....	10.3.9
	Fracture Critical Members	10.3.10
10.3.5	Evaluation	10.3.11
	NBI Component Condition Rating Guidelines.....	10.3.12
	Element Level Condition State Assessment.....	10.3.12

This page intentionally left blank.

Topic 10.3 Steel Box Beams and Girders

10.3.1

Introduction

A box girder bridge is supported by one or more steel box girder members. Steel box members are typically connected by welding. The rectangular or trapezoidal cross section of the box girder consists of two or more web plates connected to a single bottom flange plate. Although concrete box beams and concrete box girders have distinguishable differences including cross-section dimensions and shape, the terms "box beam" and "box girder" may be used interchangeably when discussing steel superstructures.

Box girder bridges are used in simple spans of 75 feet or more (see Figure 10.3.1) and in continuous spans of 100 feet or more. They are frequently used for curved bridges due to their high degree of torsional rigidity (see Figure 10.3.2).



Figure 10.3.1 Simple Span Box Girder Bridge

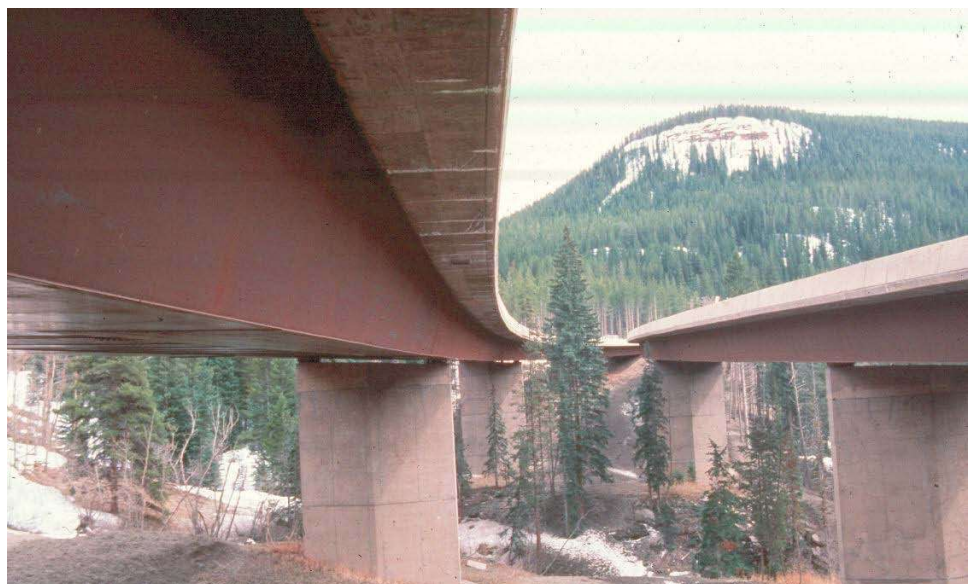

Figure 10.3.2 Curved Box Girder Bridge

10.3.2

Design Characteristics

Configuration

A box girder bridge can use a single box configuration (see Figure 10.3.3) or have multiple (spread) boxes in its cross section (see Figure 10.3.4). Several factors such as deck width, span length, terrain and even aesthetics can all play a role in determining which configuration is used.



Figure 10.3.3 Box Girders With Multiple Interior Webs



Figure 10.3.4 Spread Box Girders

Primary and Secondary Members

The primary members of a box girder bridge are the box girders (including stiffeners and internal diaphragms) and, on a curved bridge, the external diaphragms. On a straight bridge, the external diaphragms are secondary members. Diaphragms can be solid plates, rolled shapes (e.g., I-beams and channels), or cross frames constructed with angles, tee shapes, channels and plates (see Figure 10.3.5).

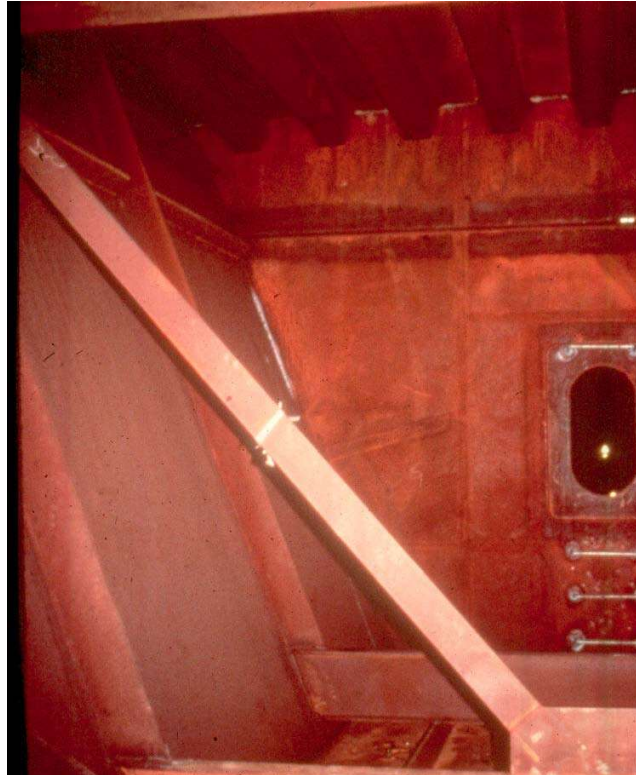

Figure 10.3.5 Diaphragms – K Bracing Internal Transverse Stiffeners

Function of an Internal Stiffener

The webs and bottom flange of large box shapes are stiffened in areas of compressive stress. This is accomplished in part by stiffeners located inside the box member. The stiffeners are designed to help the box girder resist buckling due to torsional and shear forces. The stiffeners limit the unsupported length of the web and bottom flange, which result in increased stability of the box girder. Box girders may also incorporate both diaphragm and top flange lateral bracing systems. External diaphragms may be used between box girders (see Figure 10.3.6). Box girders typically have an opening or access door to allow the bridge inspector to examine the inside of the box (see Figure 10.3.7). Box girders may be considered to be confined spaces.



Figure 10.3.6 External Diaphragm



Figure 10.3.7 Box Girder Access Door

Fracture Critical Areas Box girder bridges may be fracture critical depending on the number of box girders in the span. If the span has two or less box girders, then the structure is nonredundant and the box girders are fracture critical members.

Deck Interaction The top flange may consist of individual plates welded to the top of each web plate. If the top flange plates incorporate shear connectors, the superstructure is composite with the concrete deck. A composite deck is one in which the deck and the superstructure work together to carry the live load (see Figure 10.3.8). Alternatively, the top flange may consist of a single plate extending the width of the box. This configuration is classified as an orthotropic steel plate deck (see Figure 10.3.9). A wearing surface is then placed on the top flange as the riding surface.

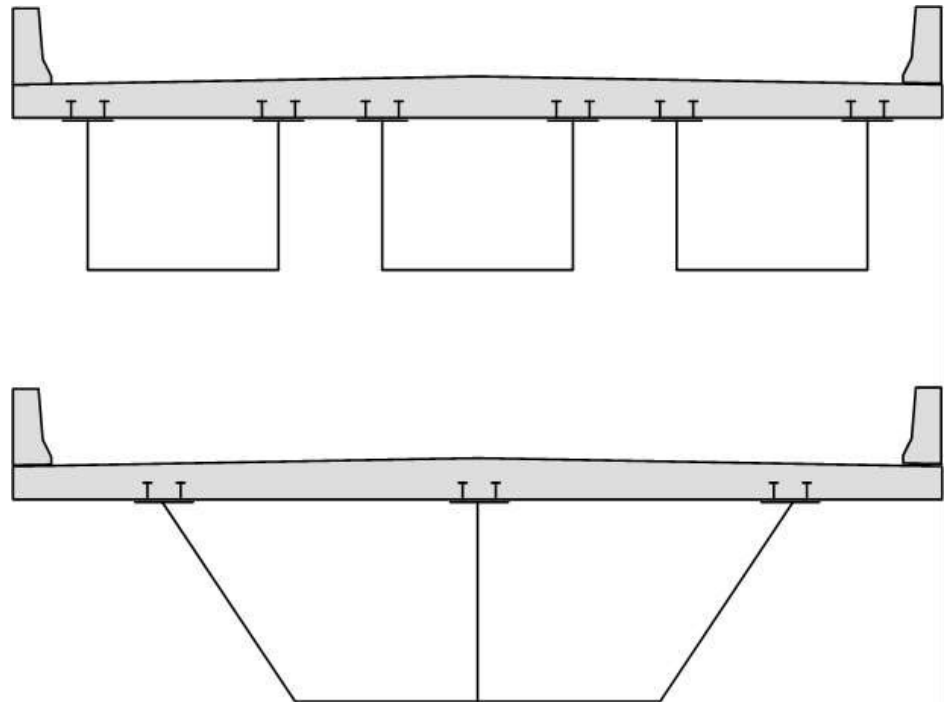

Figure 10.3.8 Box Girder Cross Section with Composite Deck

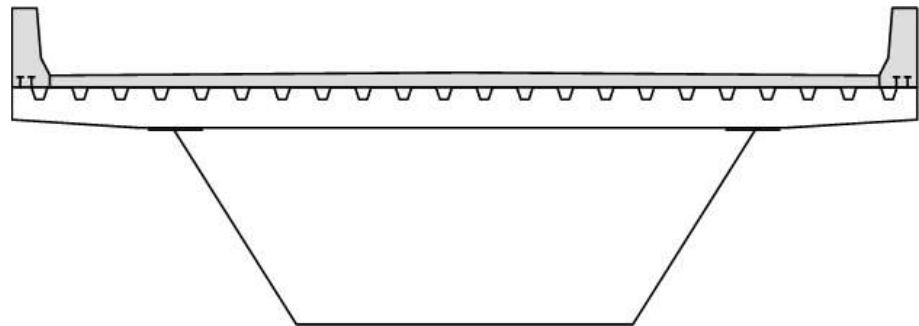

Figure 10.3.9 Box Girder Cross Section (at Floorbeam) with Orthotropic Steel Plate Deck

10.3.3

Overview of Common Deficiencies

Common deficiencies that occur on steel box girder bridges are:

- Corrosion
- Fatigue cracking
- Overloads
- Collision damage
- Heat damage
- Coating failures

See to Topic 6.3.5 for a detailed presentation of the properties of steel, types and causes of steel deterioration, and the examination of steel. Refer to Topic 6.4 for Fatigue and Fracture in Steel Bridges.

10.3.4

Inspection Methods and Locations

Inspect box girders on both the interior and the exterior. When examining the interior, exercise caution at all times. Major concerns involved with inspecting a confined space include lack of sufficient oxygen, the presence of toxic or explosive gases, unusual temperatures and poor ventilation. Also, the distance between access hatches frequently exceeds the limit that rescue crews can reach in the event of an emergency (refer to Topic 2.2, Safety Fundamentals for Bridge Inspectors, for a more detailed description of these and other safety concerns).

Inspection methods to determine other causes of steel deterioration are detailed in Topic 6.3.8.

Methods

Visual

The inspection of steel bridge members for deficiencies is primarily a visual activity.

Most deficiencies in steel bridges are first detected by visual inspection. In order for this to occur, a hands-on inspection, or inspection where the inspector is close enough to touch the area being inspected, is required. More exact visual observations can also be employed using a magnifying unit after cleaning the suspect area.

Physical

Removal of paint can be done using a wire brush, grinding, or sand blasting, depending on the size and location of the suspected deficiency. The use of degreasing spray before and after removal of the paint may help in revealing the deficiency.

When section loss occurs, use a wire brush, grinder or hammer to remove loose or flaked steel. After the flaked steel is removed, measure the remaining section and compare it to a similar section with no section loss.

The usual and most reliable sign of fatigue cracks is the oxide or rust stains that develop after the paint film has cracked. Experience has shown that cracks have

generally propagated to a depth between one-fourth and one-half the plate thickness before the paint film is broken, permitting the oxide to form. This occurs because the paint is more flexible than the underlying steel.

Smaller cracks are not likely to be detected visually unless the paint, mill scale, and dirt are removed by carefully cleaning the suspect area. If the confirmation of a possible crack is to be conducted by another person, it is advisable not to disturb the suspected crack area so that re-examination of the actual conditions can be made.

Once the presence of a crack has been verified, examine all other similar locations and details on the bridge.

Advanced Inspection Methods

Several advanced methods are available for steel inspection. Nondestructive methods, described in Topic 15.3.2, include:

- Acoustic emissions testing
- Corrosion sensors
- Smart coatings
- Dye penetrant
- Magnetic particle
- Radiographic testing
- Computed tomography
- Robotic inspection
- Ultrasonic testing
- Eddy current
- Electrochemical fatigue sensor (EFS)

Other methods, described in Topic 15.3.3, include:

- Brinell hardness test
- Charpy impact test
- Chemical analysis
- Tensile strength test

Locations

Bearing Areas

Examine the web areas over the supports for cracks, section loss and buckling. If bearing stiffeners, jacking stiffeners and diaphragms are present at the supports inspect them for cracks, section loss and buckling also.

Examine the bearings at each support for corrosion. Check the alignment of each bearing and note any movement. Report any build up of debris surrounding the bearings that may limit the bearing from functioning properly. Check for any

bearings that are frozen due to heavy corrosion. See Topic 11.1 for a detailed presentation on the inspection of bridge bearings.

Shear Zones

Examine the web areas near substructure supports for cracks, section loss and buckling (see Figure 10.3.10). Be sure to include intermediate supports provided by piers (see Figure 10.3.11).

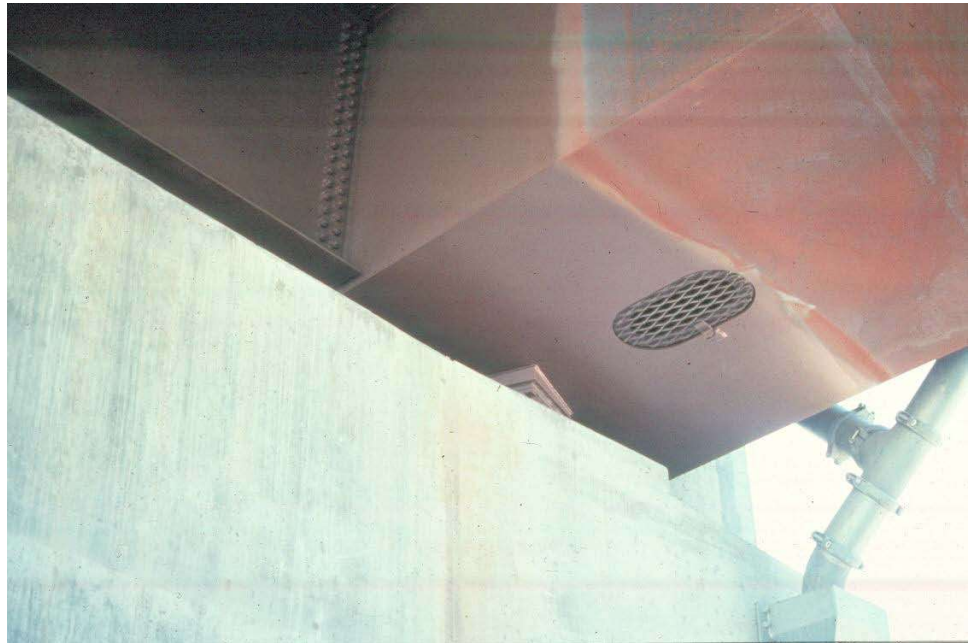

Figure 10.3.10 Box Girder Shear Zone



Figure 10.3.11 Continuous Box Girders

Flexure Zones

The flexure zone of each box girder includes the entire length between the supports (see Figure 10.3.11). Investigate the tension and compression flanges for corrosion, loss of section, cracks, dings, and gouges. Check the flanges in high stress areas for bending or flexure-related damage. Examine the compression flange for local buckling and, although it is uncommon, for elongation or fracture of the tension flange. On continuous spans, the box girders over the intermediate supports have high flexural stresses due to negative moment. If welded cover plates are present, check carefully at the ends of the cover plates for cracks.

Secondary Members

Examine the diaphragm and bracing connections for loose fasteners or cracked welds. This problem is most common on skewed bridges, and it has also been observed on bridges with a high frequency of combination truck loads. Check horizontal connection plates, which can trap debris and moisture and are susceptible to a high degree of corrosion and deterioration. Check for distorted members. Distorted secondary members may be an indication the primary members are overstressed or the substructure may be experiencing differential settlement.

Areas Exposed to Drainage

The areas that trap water and debris result in active corrosion cells and excessive loss in section. Check horizontal connection plates that can trap debris and moisture and are susceptible to a high degree of corrosion and deterioration. Areas such as diaphragm to bottom flange connections can trap water, while external lateral bracing connection plates collect bird droppings and roadway debris. On box girder bridges, check the integrity of the drainage system. No water should be gaining access to the interior of the box(es).

Some steel box girders are designed or retrofitted with small drainage holes. If present, inspect the drainage holes for blockage and corrosion.

Areas Exposed to Traffic

For box girders over a highway, railway, or navigable channel, check the box girder for signs of collision damage. Document any loss of section, cracking, scrape marks or distortion.

Problematic Details

Problematic details checked for deficiencies and deterioration include:

- Triaxial constraint
- Intersecting welds
- Cover plates
- Cantilevered suspended spans
- Insert plates
- Field welds: patch and splice plates
- Intermittent welds

- Out-of-plane bending
- Pin-and-hanger assemblies
- Back-up bars
- Mechanical fasteners and tack welds

Note that out-of-plane bending may occur at the following areas, which are presented further in Topic 6.4.8:

- Girder web connections for diaphragms and floorbeams, including connections plates at the top flange, connection plates at the bottom flange, and connection plates at the bottom flange for skewed bridges
- Lateral bracing gussets and diaphragm connection plates
- Diaphragm connections to gusset plates

In addition to the common problematic details, box girders also utilize the following:

- Stiffeners (transverse/longitudinal)
- Groove welded butt splices
- Lateral bracing gusset plates
- Web-to-flange welds
- Miscellaneous connections (railing/utilities)

See Topic 6.4.8 for additional information on problematic details.

Fracture Critical Members

The redundant nature of a box girder bridge depends primarily on the number of box girders in the span. If two or less box girders are used, the structure is considered nonredundant and the box girders are fracture critical members (see Figure 10.3.12). Bridge specific written inspection procedures should be developed for each bridge with fracture critical members. Review bridge specific inspection procedures and all previous reports before performing the inspection to note any areas of particular concern. Check all reported deficiencies to ensure no further development has occurred.

If three or more box girders are used, the structure is generally considered redundant (see Figure 10.3.13). However, if the spacing of the box girders is large, the structure may not be redundant.



Figure 10.3.12 Non-Redundant Box Girder Bridges



Figure 10.3.13 Redundant Box Girder Bridge

10.3.5

Evaluation

State and Federal rating guideline systems have been developed to aid in the inspection of steel superstructures. The two major rating guideline systems currently in use are the FHWA's *Recording and Coding Guide for the Structural Inventory and Appraisal of the Nation's Bridges* used for the National Bridge Inventory (NBI) component condition rating method and the AASHTO *Guide Manual for Bridge Element Inspection* for element level condition state assessment.

NBI Component Condition Rating Guidelines

Using NBI component condition rating guidelines, a one-digit code on the Federal Structure Inventory and Appraisal (SI&A) sheet indicates the condition of the superstructure. Component condition rating codes range from 9 to 0 where 9 is the best rating possible. See Topic 4.2 (Item 59) for additional details about NBI component condition rating guidelines.

Consider previous inspection data along with current inspection findings to determine the correct component condition rating.

Element Level Condition State Assessment

In an element level condition state assessment of a steel box girder bridge, possible AASHTO National Bridge Elements (NBEs) and Bridge Management Elements (BMEs) are:

<u>NBE No.</u>	<u>Description</u>
<u>Superstructure</u>	
102	Steel Closed Web/Box Girder

<u>BME No.</u>	<u>Description</u>
<u>Wearing Surfaces and Protection Systems</u>	
515	Steel Protective Coating

The unit quantity for the steel box girder is feet. The total length is distributed among the four available condition states depending on the extent and severity of the deficiency. The unit quantity for protective coating is square feet, with the total area distributed among the four available condition states depending on the extent and severity of the deficiency. The sum of all condition states equals the total quantity of the National Bridge Element or Bridge Management Element. Condition State 1 is the best possible rating. See the *AASHTO Guide Manual for Bridge Element Inspection* for condition state descriptions.

The following Smart Flags are applicable in the evaluation of steel box girder superstructures:

<u>Defect Flag No.</u>	<u>Description</u>
356	Steel Cracking/Fatigue
357	Pack Rust
362	Superstructure Traffic Impact (load capacity)
363	Steel Section Loss
364	Steel out-of-plane (Compression Member)

See the *AASHTO Guide Manual for Bridge Element Inspection* for the application of Defect Flags.

Table of Contents

Chapter 10 Inspection and Evaluation of Steel Superstructures

10.4	Steel Trusses	10.4.1
10.4.1	Introduction.....	10.4.1
10.4.2	Design Characteristics.....	10.4.1
	Through Truss	10.4.2
	Pony Truss.....	10.4.3
	Deck Truss.....	10.4.3
	Other Truss Applications.....	10.4.4
	Design Geometry.....	10.4.5
	Chord Members	10.4.11
	Web Members.....	10.4.12
	Diagonals.....	10.4.12
	Verticals.....	10.4.14
	Panel Points and Panels	10.4.16
	Floor System Arrangement.....	10.4.19
	Lateral Bracing	10.4.20
	Sway and Portal Bracing	10.4.22
	Primary and Secondary Members	10.4.24
	Fracture Critical Members.....	10.4.24
	Fracture Critical Member.....	10.4.24
	Truss.....	10.4.24
	Floorbeams.....	10.4.24
10.4.3	Overview of Common Deficiencies.....	10.4.25
10.4.4	Inspection Methods and Locations	10.4.25
	Methods.....	10.4.25
	Visual.....	10.4.25
	Physical.....	10.4.25
	Advanced Inspection Methods	10.4.26
	Locations	10.4.26
	Bearing Areas.....	10.4.27
	Shear Zones	10.4.27
	Tension Members.....	10.4.27
	Compression Members	10.4.32
	Gusset Plates	10.4.34
	Floor System	10.4.35
	Problematic Details.....	10.4.37
	Secondary Members.....	10.4.38
	Areas Exposed to Drainage.....	10.4.39
	Others Elements	10.4.40

10.4.5	Evaluation	10.4.41
	NBI Component Condition Rating Guidelines.....	10.4.41
	Element Level Condition State Assessment.....	10.4.41

Topic 10.4 Steel Trusses

10.4.1

Introduction

Metal truss bridges have been built since the early 1800's. They can be thought of as a deep girder with the web cut out. They are also the only bridge structure made up of triangles (see Figure 10.4.1). The original metal trusses were made of wrought iron, then cast iron, then steel. When trusses were first being built of metal, material costs were very high and labor costs were low. Because trusses were made up of many short pieces, it was cost effective to build the members in the shop and assemble them at the site. Today the higher costs of labor and the lower costs of material have limited the use of trusses to major river crossings.

10.4.2

Design Characteristics

The superstructure of a truss bridge usually consists of two parallel trusses (see Figure 10.4.2). The trusses are the main load-carrying members on the bridge. There are three types of trusses, grouped according to their position relative to the bridge deck (see Figure 10.4.2).



Figure 10.4.1 Simple Span Truss

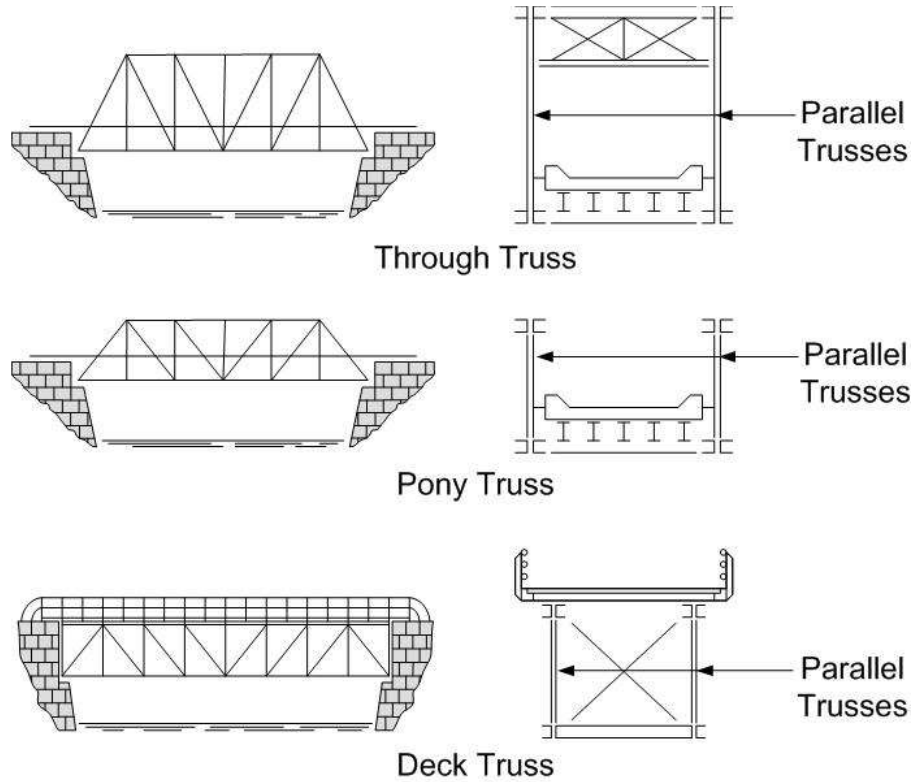

Figure 10.4.2 Through-Pony-Deck Truss Comparisons

Through Truss

On a through truss, the roadway is placed between the parallel trusses. (see Figure 10.4.3). Through trusses are constructed when underclearance is limited.



Figure 10.4.3 Through Truss

Pony Truss

A pony or "half-through" truss has no overhead bracing members connecting the two trusses (see Figure 10.4.4). The vertical height of the pony truss is much less than the height of a through truss. Today, pony trusses are seldom built, having been replaced by the multi-beam bridge.



Figure 10.4.4 Pony Truss

Deck Truss

On a deck truss, the roadway is placed on top of the parallel trusses (see Figure 10.4.5). Deck trusses have unlimited horizontal clearances and can readily be widened. For these reasons, they are preferred over through trusses when under-clearance is not a concern.



Figure 10.4.5 Deck Truss

Other Truss Applications

Trusses are generally considered to be main members. However, they are also used as floor systems in arches and as stiffening trusses in suspension bridges and arch bridges (see Figures 10.4.6 and 10.4.7). Trusses are also commonly used for movable bridge spans because they are lightweight and have higher overall stiffness (see Figure 10.4.8). Even towers are sometimes braced with web members, as a truss.



Figure 10.4.6 Suspension Bridge with Stiffening Truss



Figure 10.4.7 Deck Arch Bridge with Stiffening Truss



Figure 10.4.8 Vertical Lift Bridge

Design Geometry

Bridge engineers have used a variety of arrangements in the design of trusses. Many of the designs were patented by and named after their inventor. One characteristic that bridge trusses have in common is that the arrangement of the truss members forms triangles (see Figure 10.4.9).

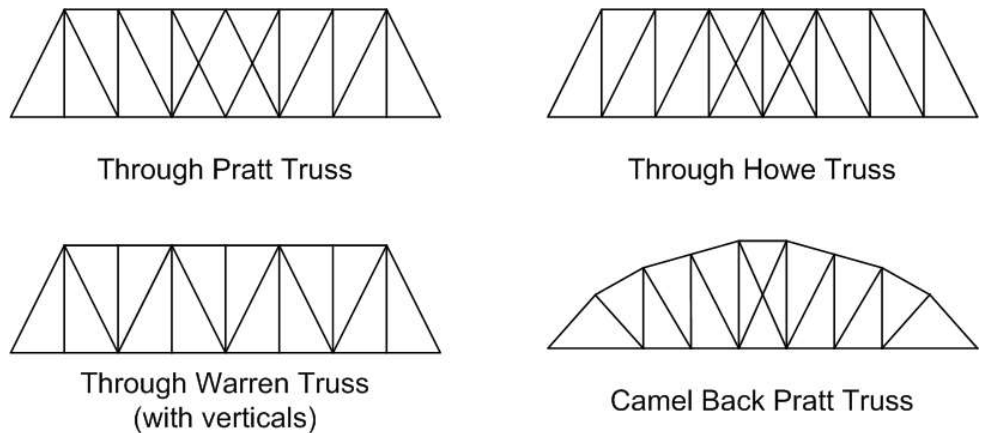

Figure 10.4.9 Various Truss Designs

Trusses have been constructed for short to very long spans, using simple, multiple and continuous designs (see Figure 10.4.10 to Figure 10.4.14). Cantilevered trusses often incorporate a "suspended" or "drop-in" span between two cantilevered spans (see Figures 10.4.15 and 10.4.16). The suspended span behaves as a simple span and is connected to cantilevered spans with pins or pin-and-hanger connections (see Figure 10.4.17). The back span on a cantilever truss is called the anchor span.



Figure 10.4.10 Single (Simple) Span Camel Back Pratt Truss



Figure 10.4.11 Single (Simple) Span Through Truss



Figure 10.4.12 Multiple Span Pony Truss



Figure 10.4.13 Multiple Span Through Truss



Figure 10.4.14 Continuous Through Truss

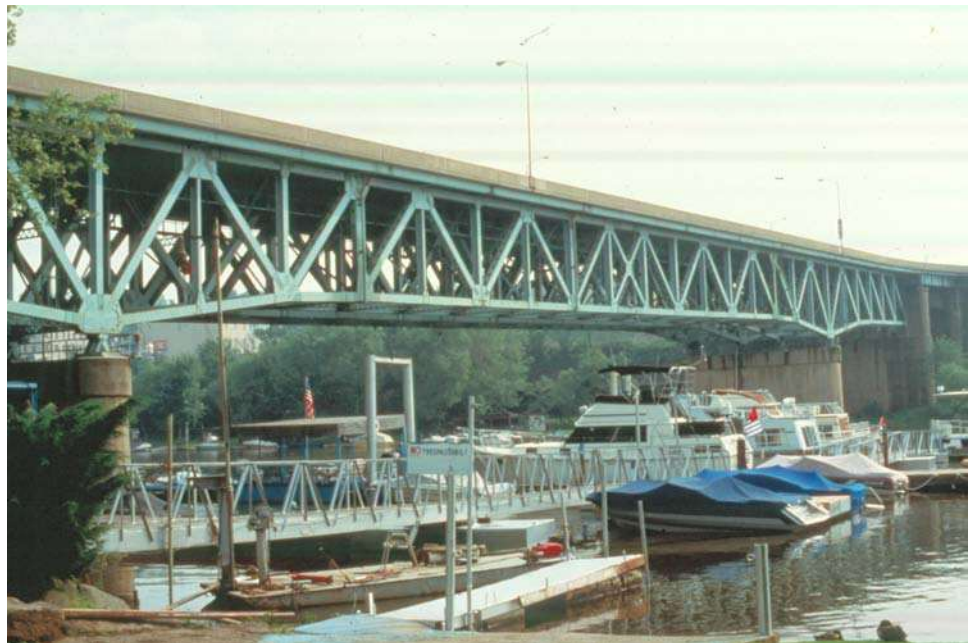

Figure 10.4.15 Cantilever Deck Truss



Figure 10.4.16 Cantilever Through Truss



Figure 10.4.17 Pin-and-Hanger Assembly for Cantilevered Truss

As stated earlier, a truss can be thought of as a very deep girder with portions of the web cut out. Truss members are divided in to three groups:

- Top or upper chord members
- Bottom or lower chord members
- Web members (diagonals and verticals)

See Figure 10.4.18 for truss members, floor systems, and various bracing configurations.

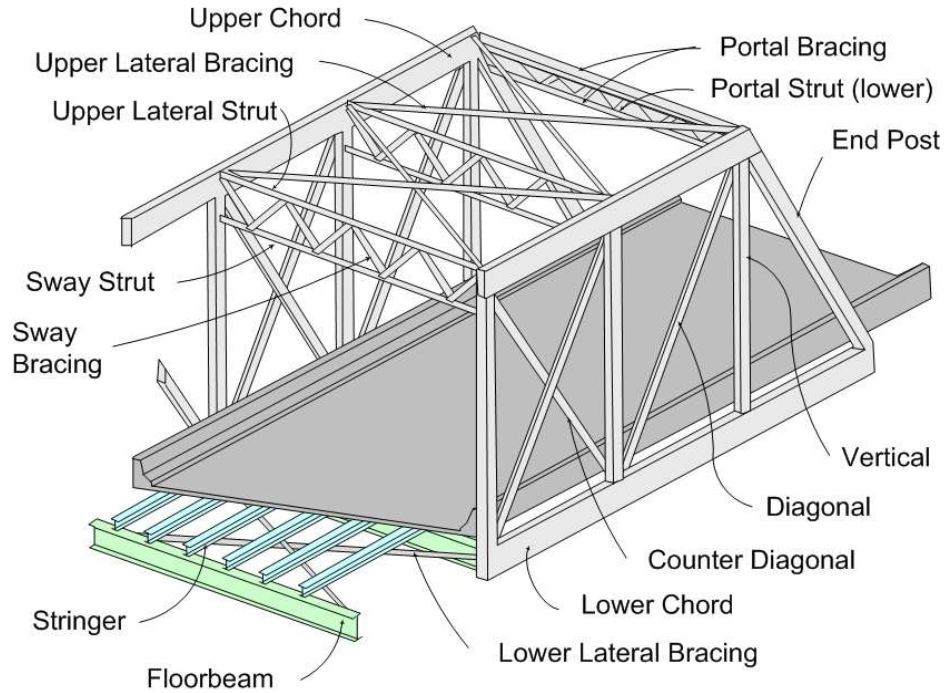

Figure 10.4.18 Truss Members, Floor Systems and Bracing

Truss members are fabricated from eyebars and rolled shapes (see Figure 10.4.19).

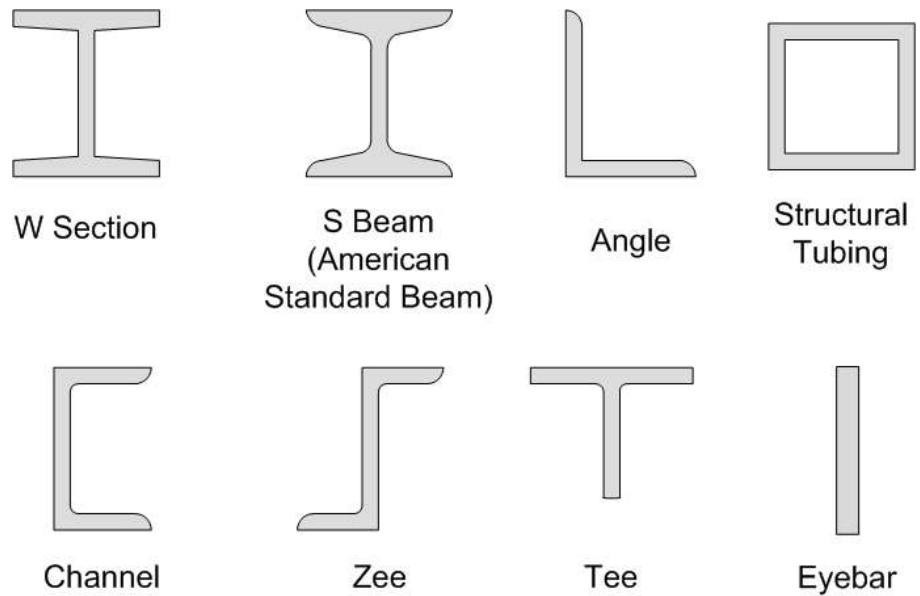

Figure 10.4.19 Rolled Steel Shapes

Trusses also utilize built-up sections. Built-up sections are fabricated by either bolting, riveting, or welding rolled shapes together. Built-up sections can also be custom designed to be efficient for expected design loads (see Figure 10.4.20). They are desirable for members that carry compression because they can be configured to resist buckling. Box sections are popular for modern trusses because they provide a “clean” look and are easier to maintain.

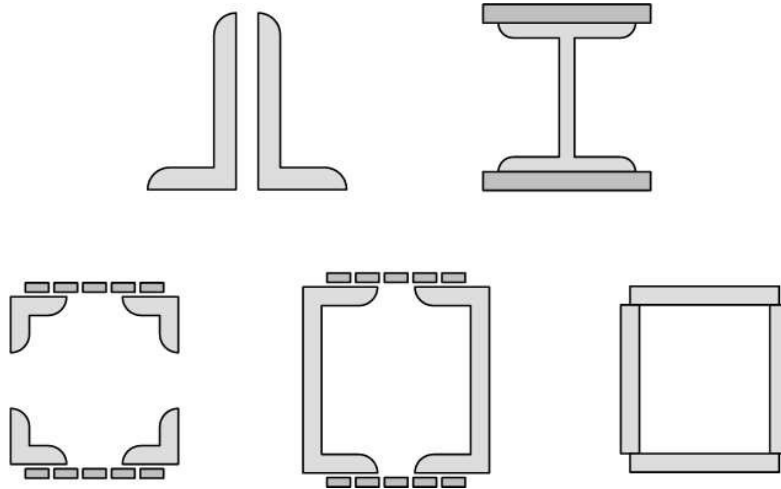

Figure 10.4.20 Built-Up Sections

Chord Members

Trusses, like beams and girders, support their loads by resisting bending. As the truss bends, the chord members behave like flanges of a beam and carry axial tension or compression forces (see Figure 10.4.21). On a simple span truss, the bottom chord is always in tension, while the top chord is always in compression. The diagonally sloped end post is a chord member. Top chords are also known as upper chords (U), and bottom chords are referred to as lower chords (L).

As truss bridge spans increase, cantilever and continuous designs are used, creating negative moment regions. Therefore, over an intermediate support, the top chord of a truss, like the top flange on a girder, is in tension (see Figure 10.4.21). It is common to find varying depth trusses on large complex structures, with the greatest depth at the supports where the moments are the largest (see Figure 10.4.14).

Simple Span

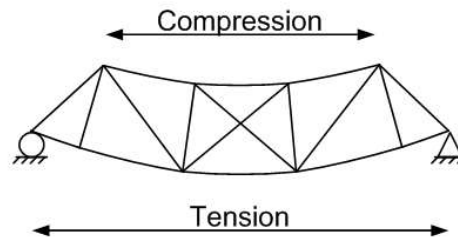

Continuous Spans

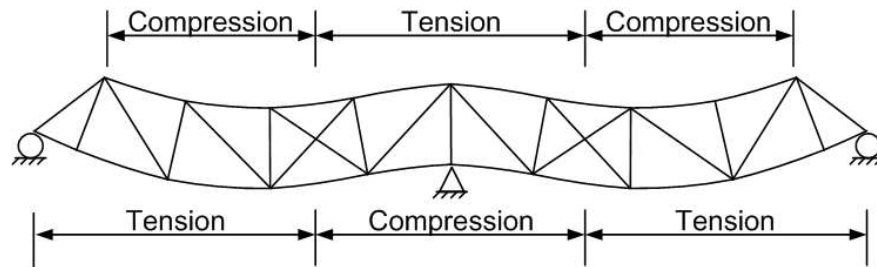

Figure 10.4.21 Axial Loads in Truss Chord Members

Web Members

The web members are typically connected to the top chord at one end and to the bottom chord at the other end. Trusses have diagonal web members, and most trusses also have vertical web members. Depending on the truss design, a web member may be in axial tension or compression, or may be subjected to force reversal and carry either type of stress for different loading conditions.

Diagonals

For simple spans, an easy method to determine when a truss diagonal is in tension or compression is to use the "imaginary cable - imaginary arch" rule (see Figure 10.4.22). Diagonals that are symmetrical about midspan and point upward toward midspan, like an arch, are in compression. Diagonals that are symmetrical about midspan and point downward toward midspan, like a cable, are in tension. This rule applies only to simple span trusses.

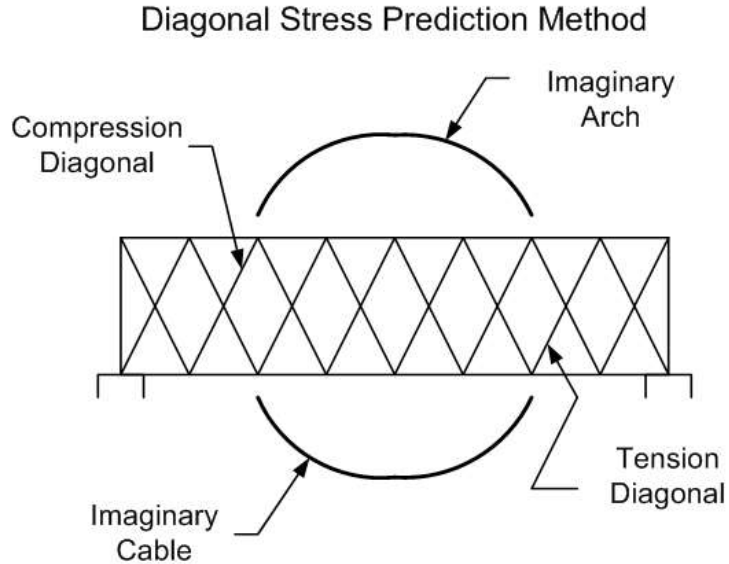

Figure 10.4.22 “Imaginary Cable – Imaginary Arch”

On older simple span trusses, the cross-section of the member can be used to determine which members are in tension and which are in compression. The design of a 25-foot member subjected to a tensile load requires a much smaller cross-member than a 25-foot member subjected to a compressive load of the same magnitude. On older pin-connected trusses, compression members are always the larger built-up members as compared to the tension members, which were often eyebar members. The Pratt truss, with its diagonals in tension, quickly replaced the Howe truss, whose diagonals are in compression. The Pratt truss is lighter and therefore less expensive to erect.

For trusses, counters are tension-resisting diagonals installed in the same panel in which the force reversal occurs. They are oriented opposite from each other, creating an "X" pattern. Counters are stressed only under live loads. On older bridges on which counters are bar shaped, they are typically capable of being moved by hand during an inspection. Counters are found on many older trusses but rarely on newer trusses.

With more complex truss designs (continuous and cantilever), the diagonal web members are capable of withstanding both axial tension and compression. This is known as force reversal, and it is one of the reasons that, on many modern truss bridges, the appearance of the tension and compression diagonals is almost identical.

As trusses become longer and, more importantly, as live loads become larger, the forces in some diagonals on a bridge continually change from tension to compression and back again. This situation occurs near the inflection points of continuous trusses. The inflection points in a continuous truss are similar to a continuous girder. The inflection points are located at the transition between positive and negative moments. Adjacent to the inflection joints, an unsymmetrical live load can cause large enough forces to overcome the symmetric dead load forces in the diagonals.

See Figure 10.4.18 of a sample truss schematic showing diagonals in a simply supported truss.

Verticals

There is also an easy method to determine when a vertical member is in tension or compression for a simply supported truss. Verticals that have one diagonal at each end are opposite to the force of the diagonals (see Figure 10.4.23). Verticals that have two diagonals at the same end are similar to the force in the diagonal closest to midspan (see Figure 10.4.24). Verticals that have counters on both ends are in compression (see Figure 10.4.25).

A vertical compression member is commonly called a post or column, while a vertical tension member is sometimes called a hanger.

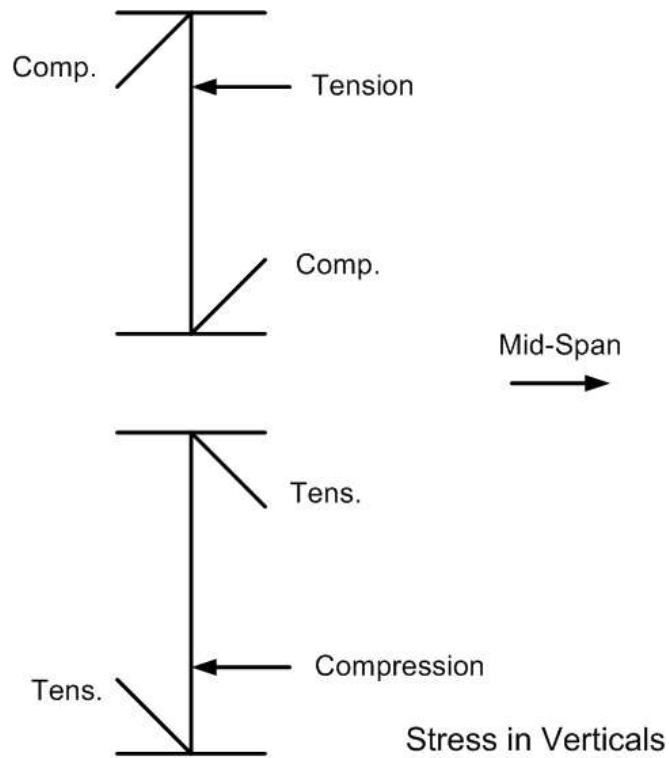

Figure 10.4.23 Vertical Member Stress Prediction Method

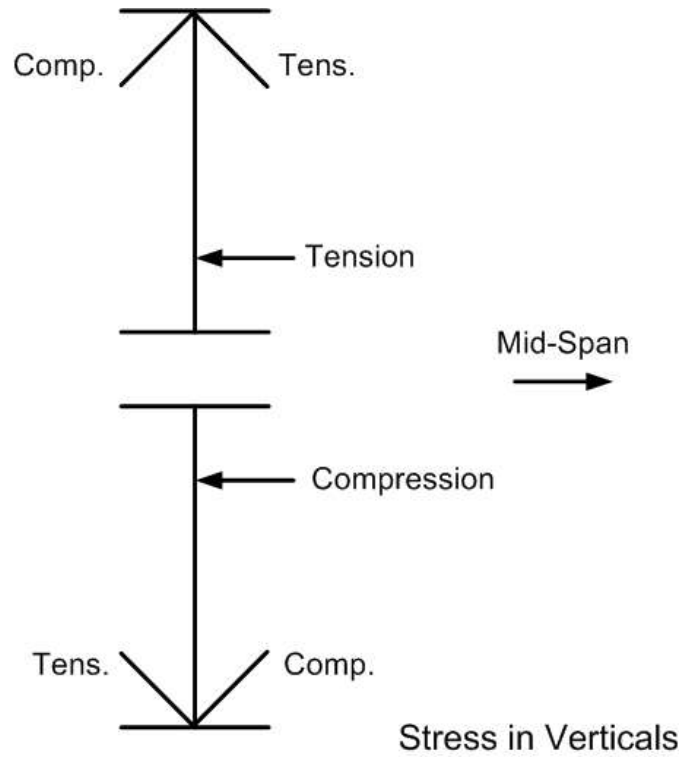

Figure 10.4.24 Vertical Member Stress Prediction Method

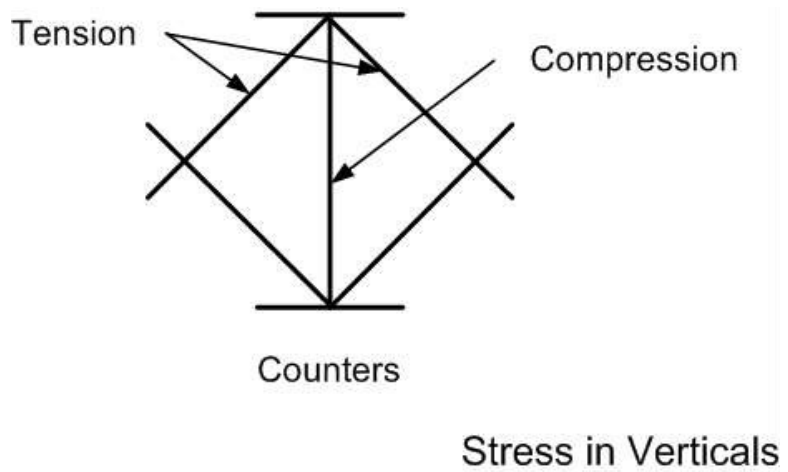

Figure 10.4.25 Vertical Member Stress Prediction Method

See Figure 10.4.18 of a sample truss schematic showing verticals in a simply supported truss.

Panel Points and Panels A panel point is the location where the truss members are connected together. Modern truss bridges are generally designed so that members have approximately the same width and depth, thereby minimizing the need for shims and filler plates at the connections. This is often accomplished by varying the plate thicknesses of built-up members or using several grades of steel to meet varying stress conditions.

The connections are typically made using gusset plates and are made by riveting, bolting, welding or a combination of these methods. Connections using both rivets and bolts were popular on bridges constructed in the late 1950's and early 1960's, as high strength bolts began to replace rivets. Rivets were used during shop fabrication while bolts were used to complete the connection in the field (see Figure 10.4.26).

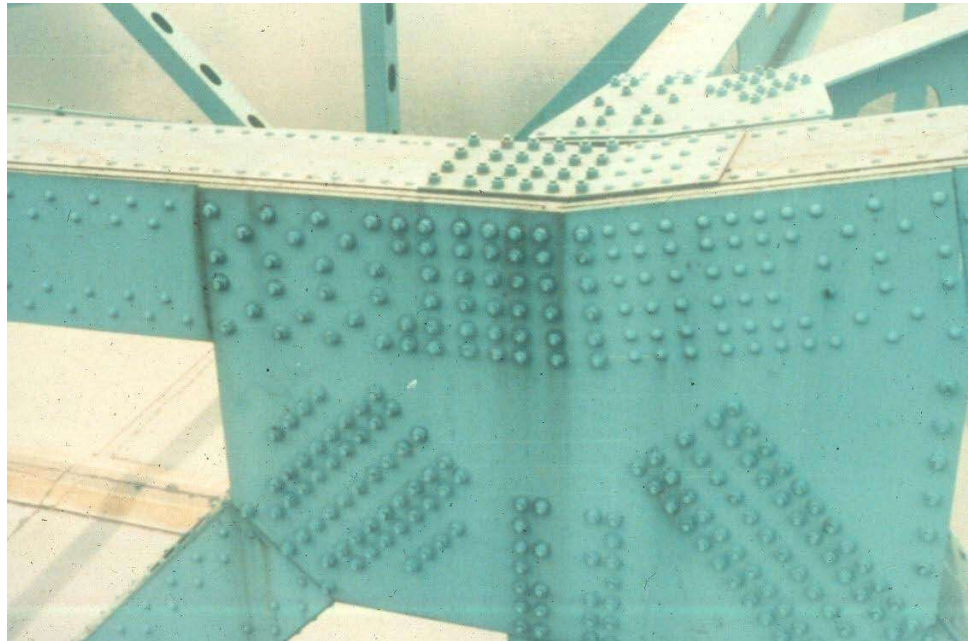

Figure 10.4.26 Truss Panel Point using Shop Rivets and Field Bolts

See Topic 10.8 for details and inspection methods of gusset plates.

Old trusses used pins at panel point connections (see Figure 10.4.27). Truss members may also be spliced, sometimes at locations other than the panel points.

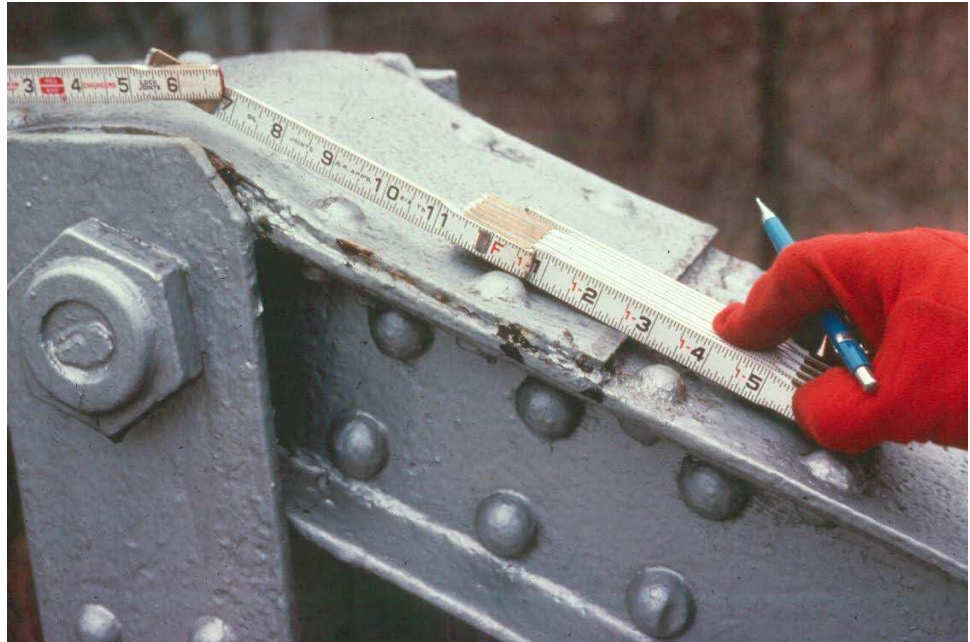

Figure 10.4.27 Pin Connected Truss

Either the letter U, for upper chord, or the letter L, for lower chord, or the letter M, for middle chord designates a panel point. Additionally, the panel points are numbered from bearing to bearing, beginning with 0 (zero). Most trusses begin with panel point L_0 . Some deck trusses may begin with U_0 . Upper and lower panel points of the same number are always in a vertical line with each other (e.g., U_7 is directly above L_7) (see Figures 10.4.28 and 10.4.29).

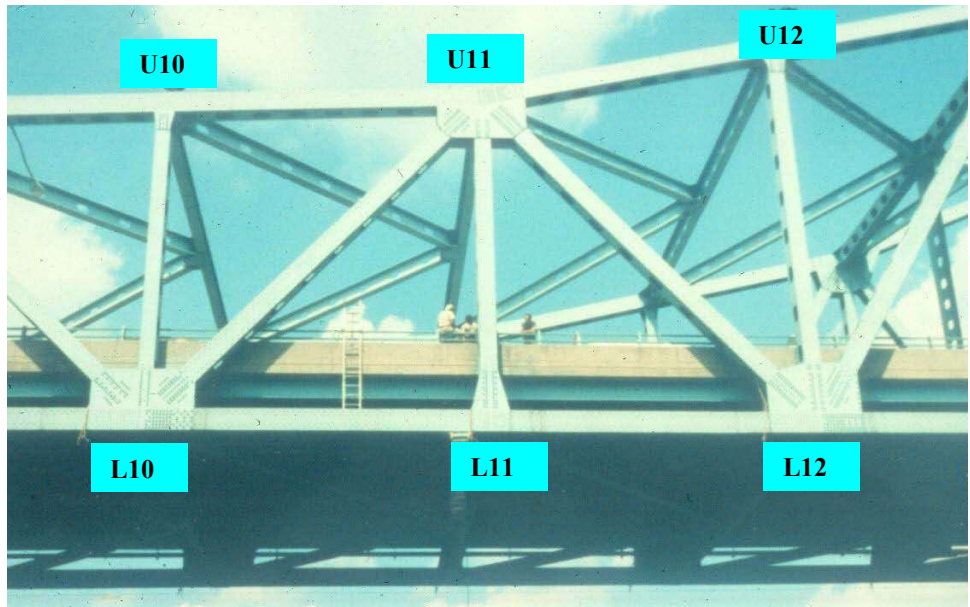

Figure 10.4.28 Truss Panel Point Numbering System

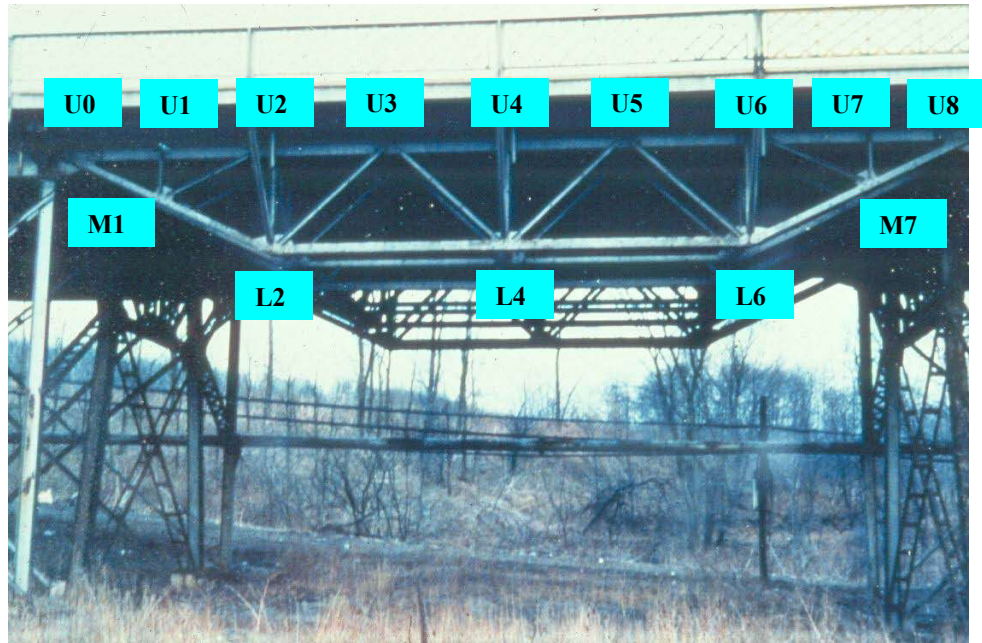

Figure 10.4.29 Deck Truss

A panel is the space, or distance, between panel points. Truss panels are typically 20 to 25 feet long and range 16 to 32 feet deep. The panel length is a design compromise between cost and weight, with the longer panels requiring heavier floor systems.

As truss spans became longer, they also had to become deeper, increasing the distance between the upper and lower chords. They also required longer horizontal distances between panel points. As the panels became longer, the diagonals became even longer and the slope became flatter. The optimum angle between the diagonal and the horizontal chord is 45 to 55 degrees.

To obtain a lighter floor system, designers subdivided the panels. The midpoint of each diagonal was braced with a downwardly inclined sub-diagonal in the opposite direction and with a sub-vertical down to the lower chord. Subpanel points are designated with the letter M. Sometimes, the "half" number of the adjoining panels is used for these diagonal midpoints (e.g., $M_{7\ 1/2}$). The method of subdividing the truss created a secondary truss system within the main truss to support additional floorbeams. Baltimore and Pennsylvania trusses, patented in the 1870's, use this method. The K truss, a more recent design, accomplishes the same purpose (see Figure 10.4.30).

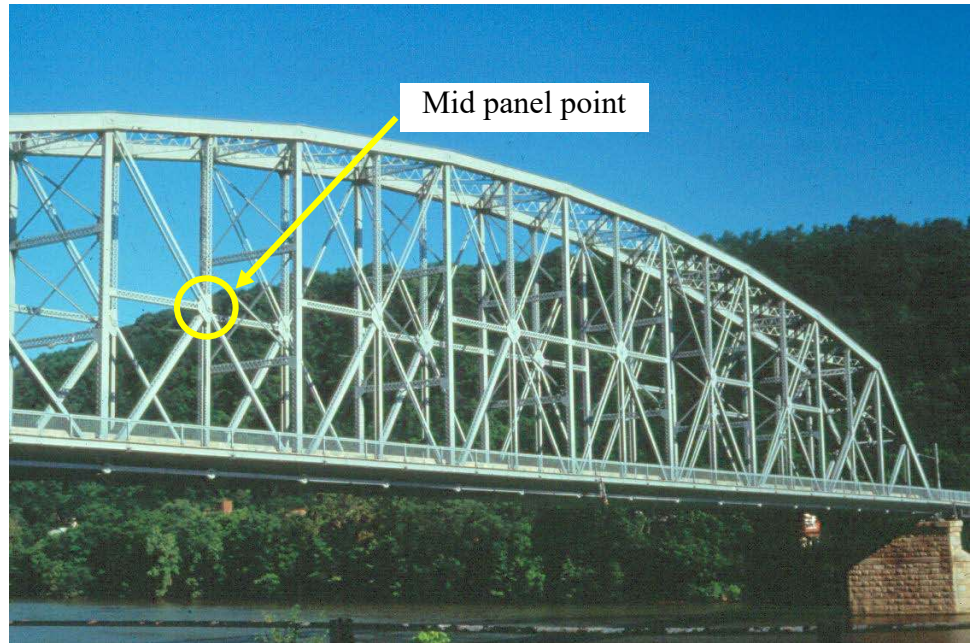

Figure 10.4.30 A Pennsylvania Truss, a Subdivided Pratt Truss with a Camel Back Top Chord

Floor System Arrangement

Most trusses have a floor system arrangement consisting of stringers and floorbeams similar to the two girder systems (see Figure 10.4.31). Floor systems support the deck and are supported by the trusses. Floor systems (floorbeams and stringers) are subjected to bending, shear and out-of-plane bending stresses. Trusses have floorbeams at each panel and sub panel point along the truss. Designate floorbeams by their panel point number. Some floor systems only contain floorbeams and no stringers (see Figure 10.4.32).

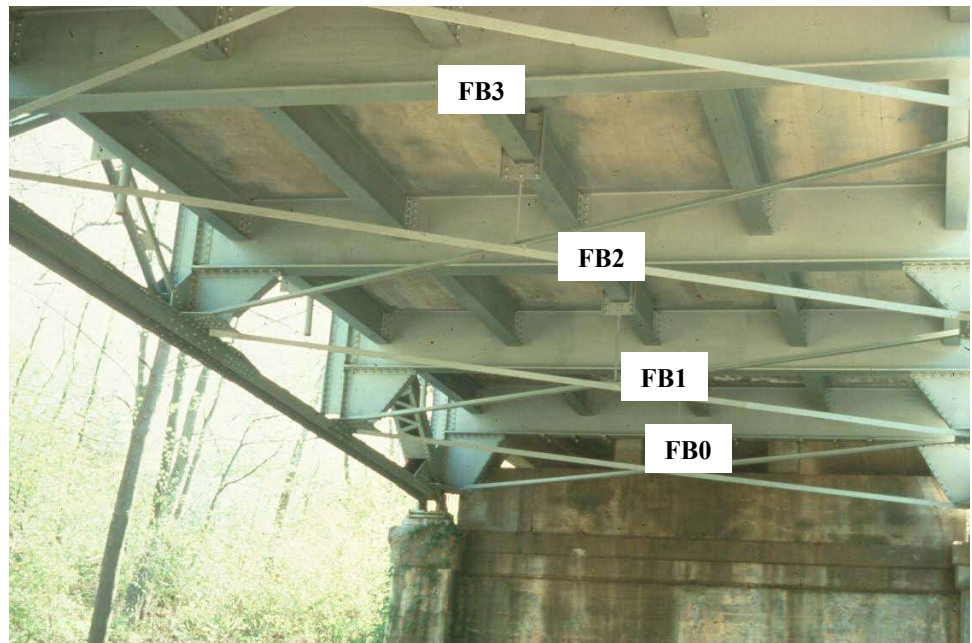

Figure 10.4.31 Floorbeam Stringer Floor System



Figure 10.4.32 Floorbeam Floor System

See Figure 10.4.18 of a sample truss schematic showing a truss floor system consisting of floorbeams and stringers.

Lateral Bracing

Upper and lower lateral bracing is in a horizontal plane and functions to keep the two trusses longitudinally in line with each other and are considered secondary members. Most trusses have upper and lower chord lateral bracing, with the exception of pony trusses, which do not have upper lateral bracing. The bracing is typically constructed from built-up or rolled shapes and is connected diagonally to the chords and floorbeams at each panel point using gusset plates (see Figure 10.4.18, Figure 10.4.33, Figure 10.4.34 and Figure 10.4.35). Lateral bracing is subjected to tensile stresses caused by longitudinal or transverse loadings.

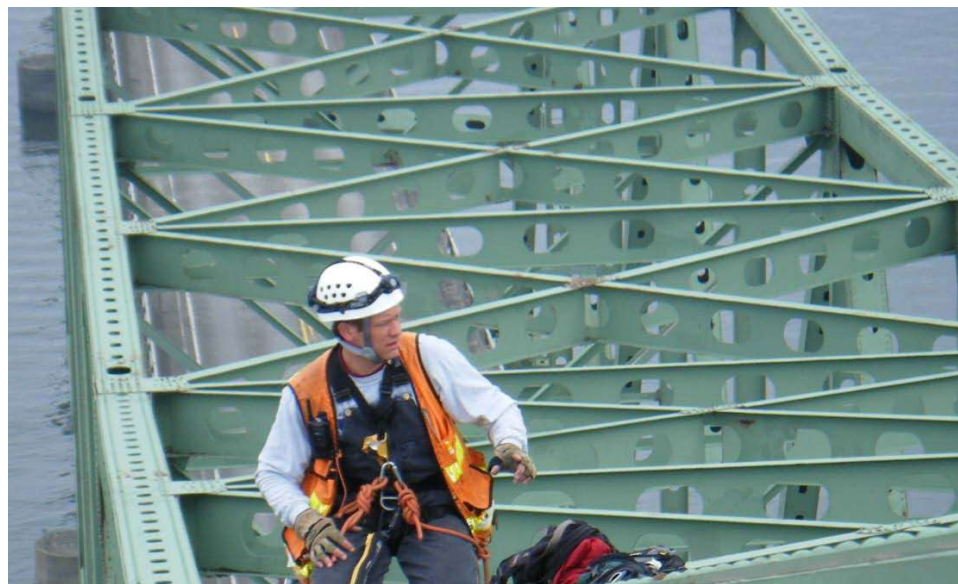

Figure 10.4.33 Inspection of Upper Lateral Bracing



Figure 10.4.34 Lower Lateral Bracing

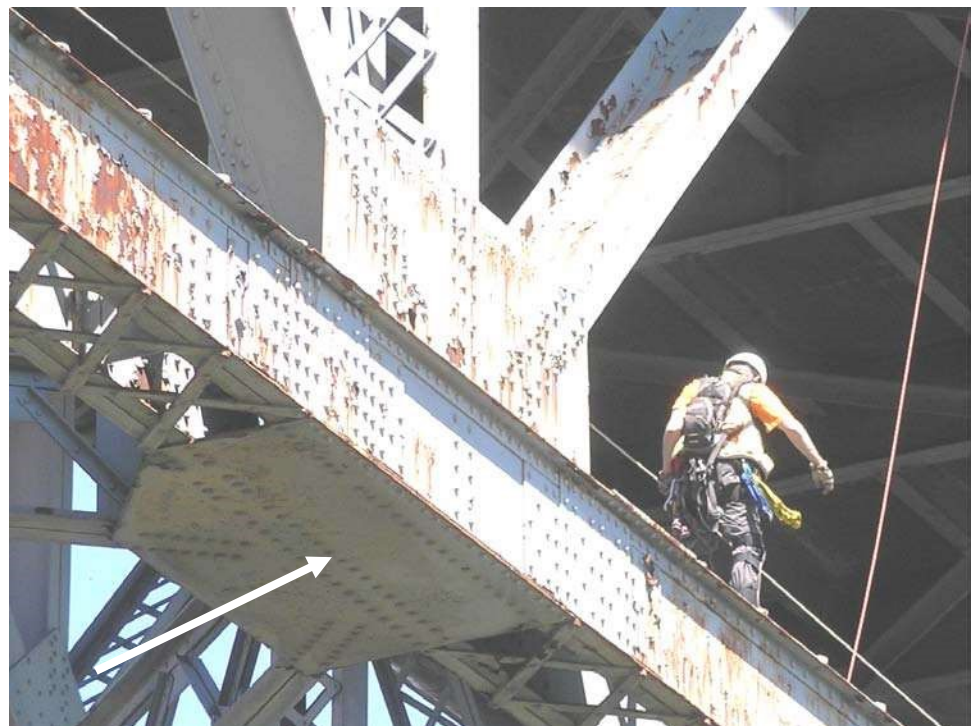

Figure 10.4.35 Lateral Bracing Gusset Plate

Sway and Portal Bracing Sway bracing is in a vertical plane and functions to keep the two trusses parallel and are considered secondary members. The bracing is typically constructed from built-up or rolled shapes. The sway bracing at the end diagonal is called portal bracing and is much heavier than the other sway bracing. Sway bracing on old through trusses often limits the vertical clearance, and it therefore often suffers collision damage. Large pony trusses also have sway bracing in the form of a transverse diagonal brace from top chord to bottom chord (see Figures 10.4.18, 10.4.36, 10.4.37, 10.4.38 and 10.4.39). Sway and portal bracing are subjected to compressive stress caused by transverse, horizontal loads. They also help resist buckling of axial compression in truss chords.

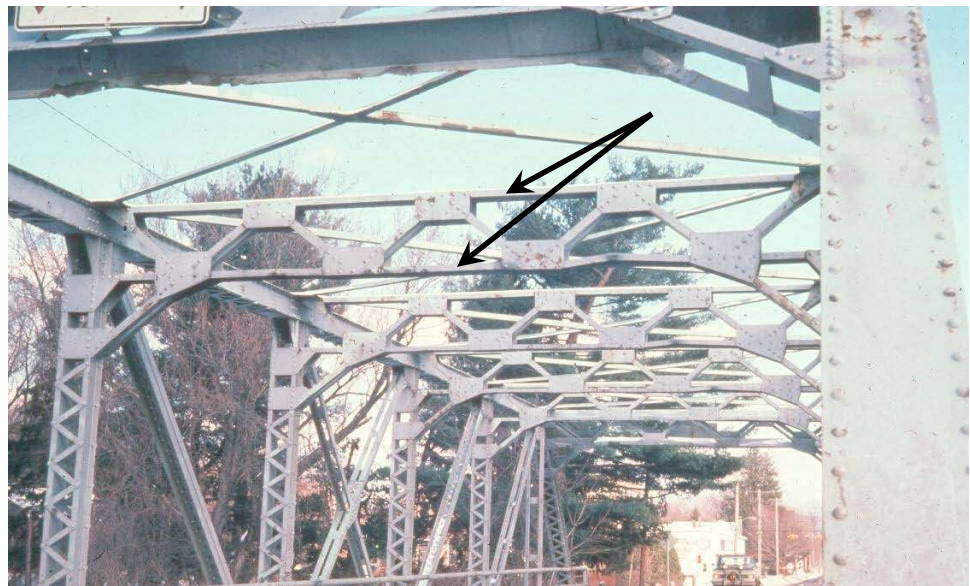

Figure 10.4.36 Sway Bracing

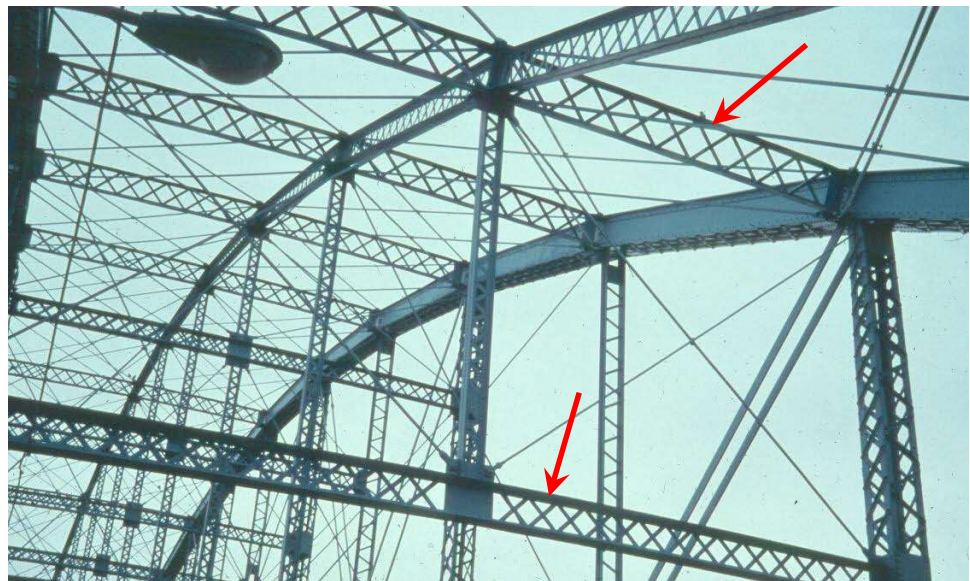

Figure 10.4.37 Sway Bracing



Figure 10.4.38 Portal Bracing with Attached Load Posting Sign

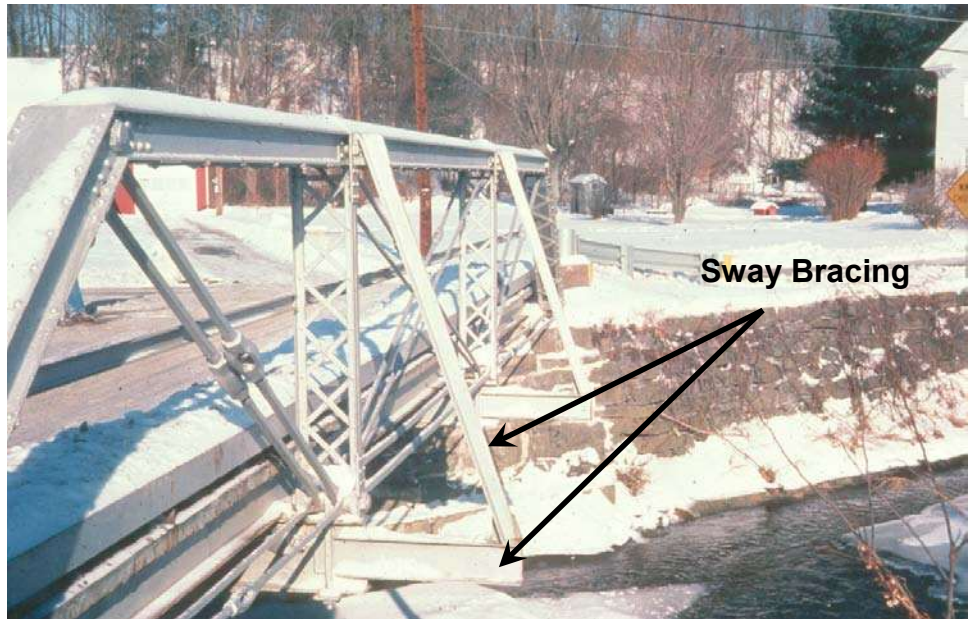

Figure 10.4.39 Pony Truss “Sway Bracing”

Primary and Secondary Members

Primary members carry permanent (dead) loads and transient (live) loads. Primary members are:

- Trusses (chords, verticals and diagonals)
- Floorbeams
- Stringers

These members are to the primary members that are evaluated during and load rating and control the load-carrying capacity of the bridge.

Secondary members resist horizontal and longitudinal loads and consist of:

- Portal bracing
- Lateral bracing
- Sway bracing

Secondary members do not contribute to the primary live load-carrying capacity of the bridge. Rather, they function only to keep the primary members properly aligned and resist secondary live loads.

Trusses, floor systems and bracing are shown on Figure 10.4.18.

Fracture Critical Members

Fracture Critical Member

A fracture critical member (FCM) is a steel member in tension, or with a tension element, whose failure would probably cause a portion of or the entire bridge to collapse.

Truss

Steel trusses are considered fracture critical since they are constructed with fracture critical members. Common fracture critical members include chords, verticals, and diagonals that experience tension and do not have load path redundancy.

Trusses are considered fracture critical since they are constructed of steel, have tension members and a failure of a tension member may have cause a portion or the entire bridge to collapse (no load path redundancy). If a truss chord, vertical or diagonal, is a tension or stress reversal member, consider it fracture critical until a detailed structural analysis is performed.

Floorbeams

Steel truss bridges have floorbeams that are considered fracture critical members if one or more of the following conditions exist:

- Flexible or hinged connection to support at the floorbeam connection
- Floorbeam spacing greater than 14'-0"
- No stringers supporting the deck
- Stringers are configured as simple beams

Some states consider any floorbeam to be fracture critical regardless of the above conditions.

A three-dimensional finite element structural analysis for fracture criticality may be performed to determine the exact consequences to the bridge if a floorbeam or floorbeam connection fails.

10.4.3

Overview of Common Deficiencies

Common deficiencies that occur on steel truss bridges are:

- Corrosion
- Fatigue cracking
- Overloads
- Collision damage
- Heat damage
- Coating failures

See Topic 6.3 for a detailed presentation of the properties of steel, types and causes of steel deterioration, and the examination of steel. Refer to Topic 6.4 for Fatigue and Fracture in Steel Bridges.

10.4.4

Inspection Methods and Locations

Inspection methods to determine causes of steel deterioration are discussed in detail in Topic 6.3.

Methods

Visual

The inspection of steel bridge members for deficiencies is primarily a visual activity.

Most deficiencies in steel bridges are first detected by visual inspection. In order for this to occur, a hands-on inspection, or inspection where the inspector is close enough to touch the area being inspected, is required. More exact visual observations can also be employed using a magnifying unit after cleaning the suspect area.

Physical

Removal of paint can be done using a wire brush, grinding, or sand blasting, depending on the size and location of the suspected deficiency. The use of degreasing spray before and after removal of the paint may help in revealing the deficiency.

When section loss occurs, use a wire brush, grinder or hammer to remove loose or flaked steel. After the flaked steel is removed, measure the remaining section and compare it to a similar section with no section loss.

The usual and most reliable sign of fatigue cracks is the oxide or rust stains that

develop after the paint film has cracked. Experience has shown that cracks have generally propagated to a depth between one-fourth and one-half the plate thickness before the paint film is broken, permitting the oxide to form. This occurs because the paint is more flexible than the underlying steel.

Smaller cracks are not likely to be detected visually unless the paint, mill scale, and dirt are removed by carefully cleaning the suspect area. If the confirmation of a possible crack is to be conducted by another person, it is advisable not to disturb the suspected crack area so that re-examination of the actual conditions can be made.

Once the presence of a crack has been verified, examine all other similar locations and details.

Advanced Inspection Methods

Several advanced methods are available for steel inspection. Nondestructive methods, described in Topic 15.3.2, include:

- Acoustic emissions testing
- Corrosion sensors
- Smart coatings
- Dye penetrant
- Magnetic particle
- Radiographic testing
- Computed Tomography
- Robotic inspection
- Ultrasonic testing
- Eddy current
- Strain evaluation
- Electrochemical fatigue sensor (EFS)

Other methods, described in Topic 15.3.3, include:

- Brinell hardness test
- Charpy impact test
- Chemical analysis
- Tensile strength test

Locations

A truss consists of members, which are primarily under axial loading only. Furthermore, many truss members are designed for force reversal. If a review of the bridge's design drawings indicates that a member is subjected to tension and compression, inspect the member as a tension member subjected to cracking or elongation or as a compression member subjected to buckling (see Figure 10.4.40). Floor systems experience shear forces, tension and compression stresses caused by bending moments.

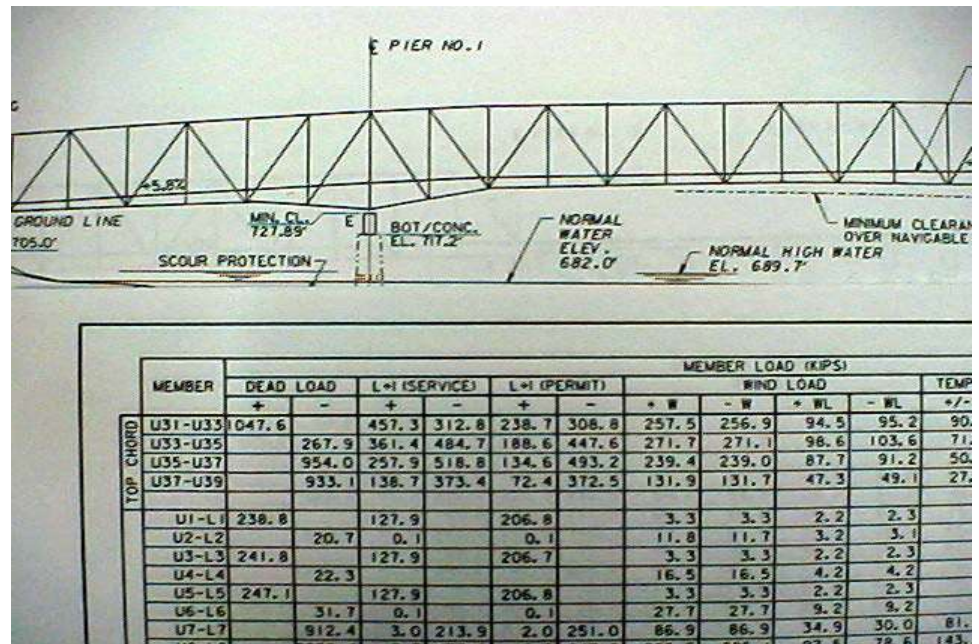

Figure 10.4.40 Truss Design Drawings: Member Load Table

Bearing Areas

Examine the web areas of the stringers, floorbeams and truss members over their supports for cracks, section loss and buckling. If web stiffeners are present at the supports, inspect them for cracks, section loss and buckling.

Examine the bearings at each support for corrosion. Check the alignment of each bearing and note any movement. Report any build up of debris surrounding the bearings that may limit the bearing from functioning properly. Check for any bearings that are frozen due to heavy corrosion. See Topic 11.1 for a detailed presentation on the inspection of bearings.

Shear Zones

Examine the web areas near the supports for any section loss or buckling. Shear stresses are greatest near the supports. Therefore, the condition of the web is more critical near the supports than at mid-span. Also investigate the web for buckling due to overloads.

Tension Members

For truss members subjected to tensile loads, give special attention to the following locations:

- Check for section loss (corrosion) and cracks (see Figure 10.4.41).
- For box-shaped chord members, check inside for debris and corrosion, cracks or section loss (see Figure 10.4.42).
- Examine eyebar heads for cracks in the eyes and in the forge zone (see Figure 10.4.43).

- Check loop rods for cracking where the loop is formed (see Figure 10.4.44).
- Where multiple eyebars make one member, check that the tension is evenly distributed and that each eyebar within the member is parallel and evenly spaced to the adjacent eyebar. (see Figure 10.4.45).
- Check eyebars or loop rods where attachments are welded to them, especially if such attachments connect the eyebars together (see Figure 10.4.46).
- Determine whether the spacers on the pins are holding the eyebars and loop rods in their proper positions.
- Look for repairs, especially welded repairs, if they have been applied to steel tension members. Base metal cracks can develop at these locations (see Figure 10.4.46).
- Check the alignment of the members; make sure they are straight and not bowed, as this could be a sign of pier movement, collision damage or unintentional force reversal (see Figure 10.4.47).
- A member may be experiencing loads that were not intended during design, such as a member designed for tension that is now in compression. An example of this is a buckled bottom chord member in a simply supported truss (see Figures 10.4.47 and 10.4.48). Look for causes of the unintended loading and also look at adjacent members, which may be overstressed.
- Check the counters for excessive wear and abnormal rubbing where the counters cross.
- Check the tension in threaded members. Pull transversely (by hand) to check the relative tension. Proper tension allows the counter to move slightly. If improper tension is found, do not adjust the turnbuckle. Instead, promptly notify the designated point of contact for the bridge owner.



Figure 10.4.41 Corrosion and Section Loss on Truss Bottom Chord

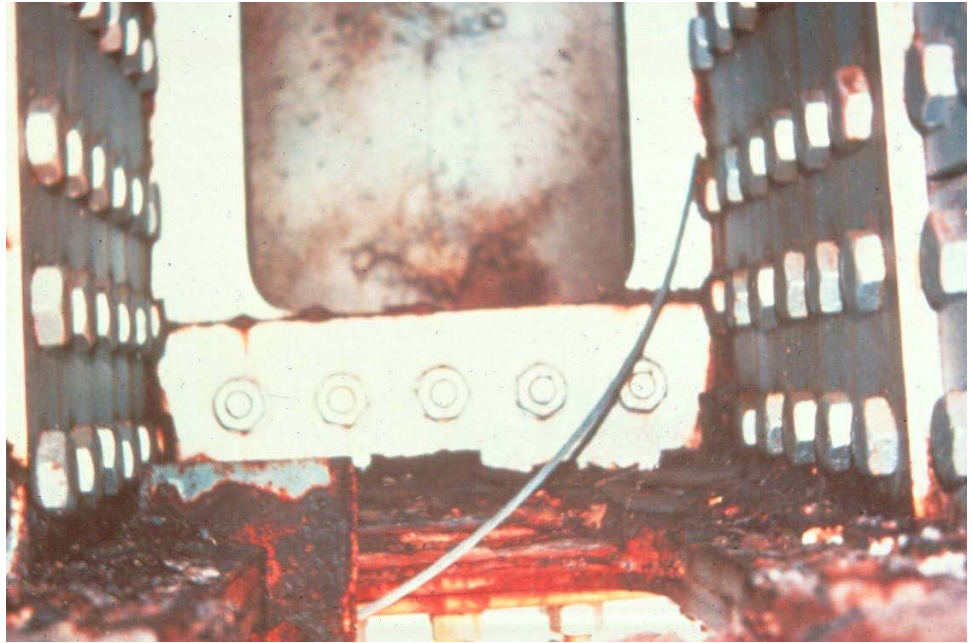

Figure 10.4.42 Inside of Box Chord Member



Figure 10.4.43 Cracked Forge Zone on an Eyebar



Figure 10.4.44 Cracked Forge Zone on a Loop Rod



Figure 10.4.45 Bottom Chord with Eyebars

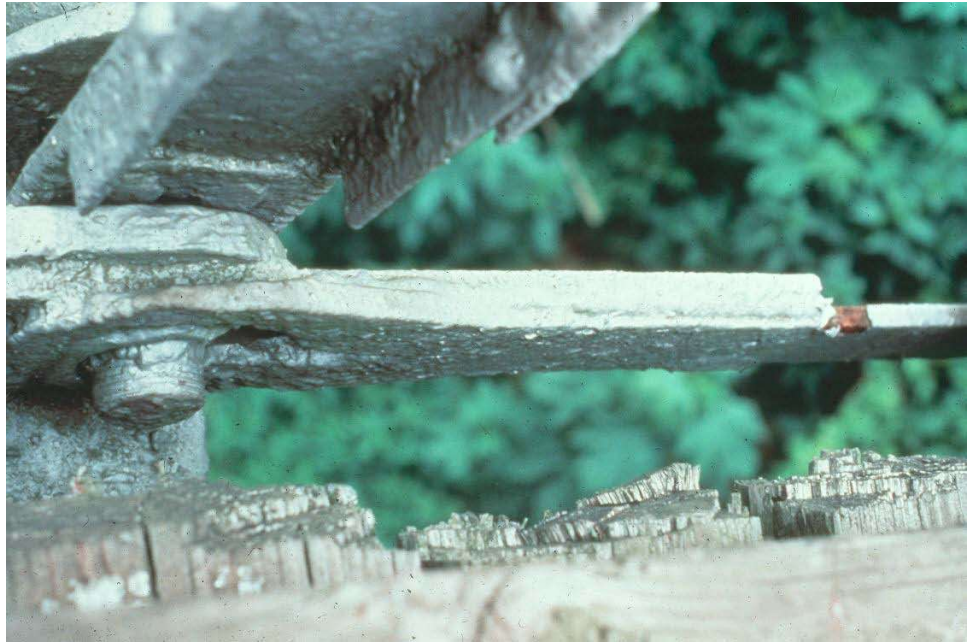

Figure 10.4.46 Welded Repair to Loop Rod



Figure 10.4.47 Bowed Bottom Chord Eyebar Member



Figure 10.4.48 Buckled Bottom Chord Member, Due to Abutment Movement

On trusses with cantilevered and suspended spans, the pin-connected joints that permit expansion are susceptible to freezing or fixity of the pinned joints. This can result in undesirable stresses in the structure - changing axial loaded members to bending members. Carefully inspect the pins at such connections for corrosion, section loss, and fixity.

Compression Members

For truss members subjected to compressive loads, give special attention to the following locations:

- End posts, verticals and diagonals, which are vulnerable to collision damage from passing vehicles. Buckled, torn, or misaligned members may severely reduce the load carrying capacity of the member (see Figure 10.4.49).
- Check for local buckling, an indication of overstress (see Figure 10.4.50).
- Wrinkles or waves in the flanges, webs or cover plate are common forms of buckling.

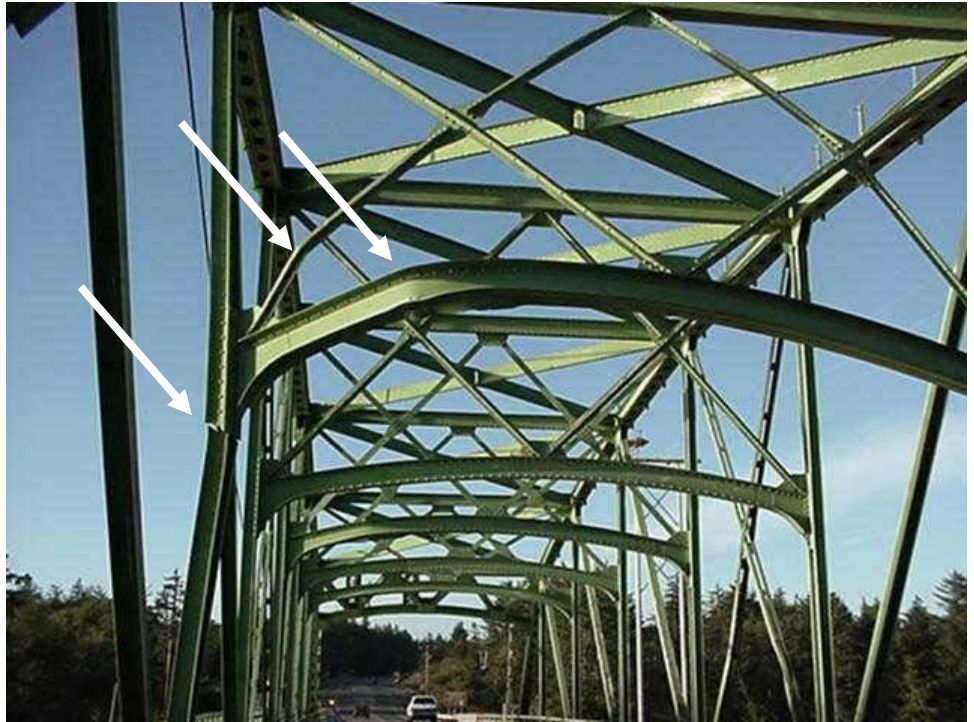

Figure 10.4.49 Collision Damage to Truss Members Due to Overheight Vehicle



Figure 10.4.50 Buckled End Post

Gusset Plates

For most truss bridges, gusset plates are the primary method of connecting individual truss members (chords, diagonals, verticals) together. Gusset plates may also be used to connect bracing members together. Unlike ordinary truss members, gusset plates experience axial tension and compression forces and shear forces simultaneously and subsequently require thorough inspection.

For steel truss gusset plates, give special attention to the following locations:

- Look for out-of-plane distortions particularly at areas susceptible to pack rust and along areas of unbraced length.
- Check for coating system failures, as these allow for advancement of corrosion and section loss (see Figure 10.4.51).
- Check for corrosion and section loss, comparing current measurements to original drawings.
- Check for cracking around tack welds, bolt and rivet holes, and other welds.
- Examine the gusset plate for loose or broken bolts and rivets, which can be detected through hammer sounding.
- Closely examine gusset plate retrofits, particularly welded retrofits as they can be problematic.

Refer to Topic 10.8.4 for detailed information on inspection locations and methods for gusset plates.

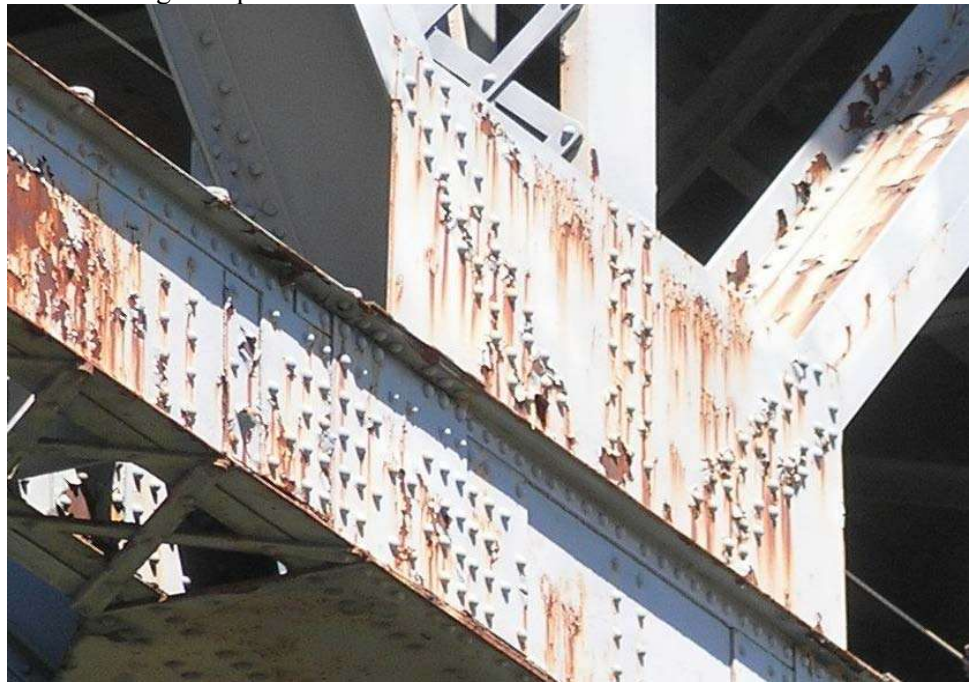

Figure 10.4.51 Gusset Plate Connection with Coating System Failure

Floor System

The floor system on a truss contains floorbeams and possibly stringers. These members function as beams and are subjected to bending, shear and out-of-plane bending stresses. Distortion induced fatigue cracks have also developed in the webs of many floorbeams at connections to truss bridge lower chord panel points when the stringers are placed above the floorbeams. The webs of these floorbeams at the connections and adjacent to flanges and stiffeners are inspected for signs of buckling.

For steel truss floor systems, give special attention to the following locations:

- Check the end connections of floorbeams for corrosion as they are exposed to moisture and deicing chemicals from the roadway (see Figure 10.4.52).
- Check the floorbeams and stringers for corrosion, particularly under open grid decks (see Figure 10.4.53).
- Check floor system member flanges and webs for corrosion and cracks (see Figures 10.4.54 and 10.4.55).
- During the passage of traffic, listen for abnormal noises caused by moving members and loose connections.



Figure 10.4.52 Corroded Floorbeam End and Connection with Deicing Chemical Residue



Figure 10.4.53 Corroded Stringers under an Open Grid Deck



Figure 10.4.54 Corroded End of Stringer



Figure 10.4.55 Corroded Floorbeams and Stringers

Problematic Details

Problematic details checked for deficiencies and deterioration include:

- Triaxial constraint
- Intersecting welds
- Cover plates
- Cantilevered suspended spans
- Insert plates
- Field welds: patch and splice plates
- Intermittent welds
- Out-of-plane bending
- Pin-and-hanger assemblies
- Back-up bars
- Mechanical fasteners and tack welds

Note that out-of-plane bending may occur at the following areas, which are presented further in Topic 6.4.8:

- Lateral bracing gussets and diaphragm connection plates

In addition to common problematic details, trusses also utilize the following:

- Stiffeners (transverse and longitudinal)
- Groove welded butt splices
- Lateral bracing gusset plates
- Web-to-flange welds
- Misc. connections (railing and utilities)

See Topic 6.4.8 for additional information on problematic details.

Secondary Members

Investigate the diaphragms, if present, and the connection areas of the lateral bracing for cracked welds, fatigue cracks, and loose fasteners. Check the lateral bracing gusset plates for corrosion. These horizontal plates typically deteriorate more rapidly than other elements on a truss because they are exposed to, and retain, moisture and deicing salts (see Figure 10.4.35). Inspect the bracing members for any distortion, or corrosion and pack rust (see Figure 10.4.57 and Figure 10.4.58). Distorted or cracked secondary members may be an indication the primary members may be overstressed or the substructure may be experiencing differential settlement.

For steel truss secondary members, check for collision damage at the portals and at knee braces (see Figure 10.4.56).



Figure 10.4.56 Collision Damage to Portal



Figure 10.4.57 Lateral Bracing with Corrosion



Figure 10.4.58 Sway Bracing with Pack Rust

Areas Exposed to Drainage

Check horizontal surfaces that can trap debris and moisture and are susceptible to a high degree of corrosion and deterioration. Areas that trap water and debris can result in active corrosion cells and excessive loss in section. This can result in notches susceptible to fatigue or perforation and loss of section.

On steel truss bridges check:

- Areas exposed to drainage runoff
- Lateral bracing gusset plates
- Inside built-up chord members (horizontal surfaces)
- Pockets created by floor system connections
- Tightly packed panel points
- Pin-and-hanger assemblies
- Bottom flanges of chord members and floor system

Other Elements

Inspect chord members for corrosion, examining horizontal surfaces where moisture can collect. Check for corrosion and general deterioration of the lacing bars, stay plates, and batten plates (see Figure 10.4.59).

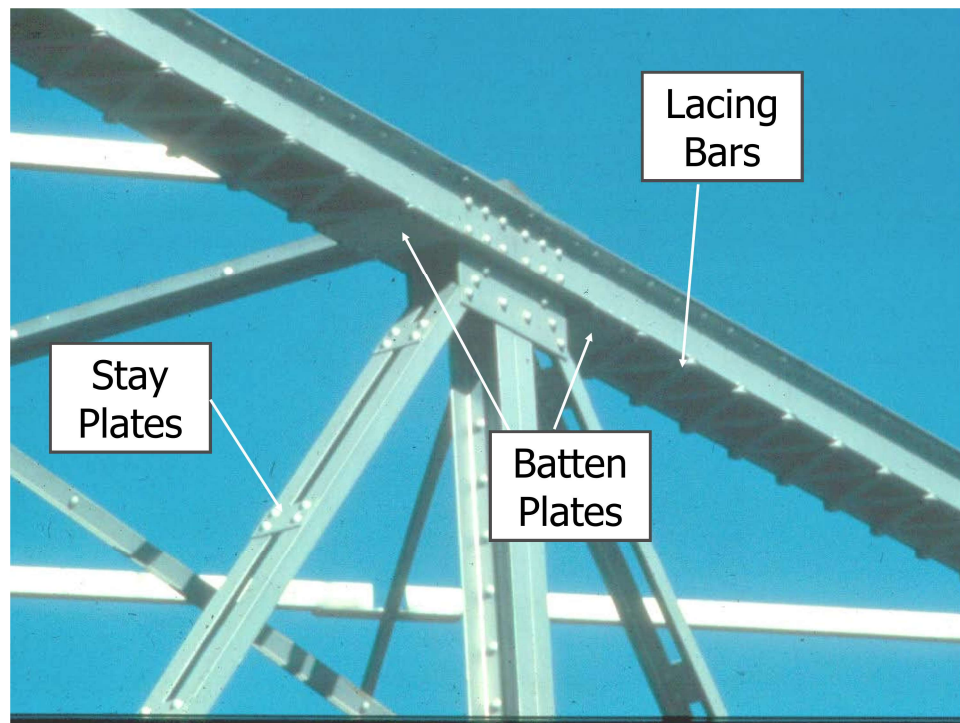

Figure 10.4.59 Other Elements

10.4.5

Evaluation

State and Federal condition rating guideline systems have been developed to aid in the inspection of steel superstructures. The two major condition rating guideline systems currently in use are the FHWA's *Recording and Coding Guide for the Structural Inventory and Appraisal of the Nation's Bridges* used for the National Bridge Inventory (NBI) component condition rating method and the AASHTO *Guide Manual for Bridge Element Inspection* for element level condition state assessment.

NBI Component Condition Rating Guidelines

Using NBI component condition rating guidelines, a one-digit code on the Federal Structure Inventory and Appraisal (SI&A) sheet indicates the condition of the superstructure. Component condition rating codes range from 9 to 0 where 9 is the best rating possible. See Topic 4.2 (Item 59) for additional details about NBI component condition rating guidelines.

The component condition rating is only influenced by the condition of the primary load-carrying members.

Deficiencies such as corrosion, section loss, and fatigue cracks impact the superstructure rating. Note the location, dimensions and extent of the deficiencies on inspection forms and include supporting sketches and photos.

Consider previous inspection data along with current inspection findings to determine the correct component condition rating.

Element Level Condition State Assessment

In an element level condition state assessment of steel trusses, possible AASHTO National Bridge Elements (NBEs) and Bridge Management Elements (BMEs) are:

<u>NBE No.</u>	<u>Description</u>
<u>Superstructure</u>	
113	Steel Stringer
120	Steel Truss
152	Steel Floor Beam
161	Steel Pin, Pin-and-Hanger Assembly, or both
162	Steel Gusset Plate
<u>BME No.</u>	<u>Description</u>
<u>Wearing Surfaces and Protection Systems</u>	
515	Steel Protective Coating

The unit quantity for the trusses, stringers (if applicable), and floorbeams is feet. The total length is distributed among the four available condition states depending on the extent and severity of the deficiency. Note that the length of a truss is measured as the distance of each truss panel longitudinal to the roadway. The unit quantity for pins (if applicable) and gusset plates is each, with the total

quantity distributed among the four available condition states depending on the severity of the deficiency. The unit quantity for steel protective coating is square feet, and the total area is distributed among the four conditions states depending on the extent and severity of the deficiency. The sum of all condition states equals the total quantity of the National Bridge Element or Bridge Management Element. Condition State 1 is the best possible rating. See the *AASHTO Guide Manual for Bridge Element Inspection* for condition state descriptions. For pin-and-hanger assemblies, see Topic 10.7. For gusset plates, see Topic 10.8.

The following Defect Flags are applicable in the evaluation of steel truss superstructures:

<u>Deflect Flag No.</u>	<u>Description</u>
356	Steel Cracking/Fatigue
357	Pack Rust
362	Superstructure Traffic Impact (load capacity)
363	Steel Section Loss
364	Steel out-of-plane (Compression Member)

See the *AASHTO Guide Manual for Bridge Element Inspection* for the application of Defect Flags.

Table of Contents

Chapter 10 Inspection and Evaluation of Steel Superstructures

10.5	Steel Arches	10.5.1
10.5.1	Introduction.....	10.5.1
10.5.2	Deck Arch Design Characteristics	10.5.2
	General	10.5.2
	Primary and Secondary Members	10.5.5
	Load Transfer	10.5.6
	Fracture Critical Members.....	10.5.6
10.5.3	Through Arch Design Characteristics.....	10.5.7
	General	10.5.7
	Primary and Secondary Members	10.5.8
	Load Transfer	10.5.9
	Fracture Critical Members.....	10.5.9
10.5.4	Tied Arch Design Characteristics	10.5.9
	General	10.5.9
	Primary and Secondary Members	10.5.10
	Load Transfer	10.5.11
	Fracture Critical Members.....	10.5.11
10.5.5	Overview of Common Deficiencies.....	10.5.11
10.5.6	Inspection Methods and Locations	10.5.12
	Methods.....	10.5.12
	Visual	10.5.12
	Physical.....	10.5.12
	Advanced Inspection Methods.....	10.5.12
	Locations	10.5.13
	Bearing Area	10.5.13
	Flexure Zones.....	10.5.13
	Arch Members	10.5.14
	Spandrel Members (Deck Arch)	10.5.15
	Hangers (Through and Tied Arches)	10.5.15
	Gusset Plates.....	10.5.17
	Tied Arches and Tied Girder	10.5.17
	Problematic Details.....	10.5.18
	Secondary Members.....	10.5.19
	Areas Exposed to Traffic	10.5.20
	Areas Exposed to Drainage.....	10.5.20

10.5.7	Evaluation	10.5.21
	NBI Component Condition Rating Guidelines.....	10.5.21
	Element Level Condition State Assessment.....	10.5.21

Topic 10.5 Steel Arches

10.5.1

Introduction

Arches are a unique form of bridge in that they look like a half circle or ellipse, turned upside down. Arch bridges have been built since Roman times, but steel arch bridges have only been constructed since the late 1800's. Arch bridges generally need strong foundations to resist the large concentrated diagonal loads.

Arches are divided into three types: deck, through, and tied (see Figures 10.5.1, 10.5.2, and 10.5.3).



Figure 10.5.1 Deck Arch Bridge



Figure 10.5.2 Through Arch Bridge



Figure 10.5.3 Tied Arch Bridge

10.5.2

Deck Arch Design Characteristics

General

Deck arches are considered to be “simple span” because of the basic arch function, even though many bridges of this type consist of multiple arches. The arch reactions, with their massive horizontal thrusts, are diagonally oriented and transmitted to the foundation.

Like its concrete counterpart, the steel open spandrel arch is designed to resist a load combination of axial compression and bending moment. The open spandrel steel arch is considered a deck arch since the roadway is above the arches (see Figure 10.5.4). The area between the arches and the roadway is called the spandrel.

Open spandrel steel arches receive traffic loads through spandrel bents that support a deck and floor system. Steel deck arches can be used in very long spans, measuring up to 1700 feet.



Figure 10.5.4 Deck Arch

The arch members are called ribs and can be fabricated in to I-shapes, boxes, or truss shapes. The arches are classified as either solid ribbed, braced ribbed, or spandrel braced (see Figures 10.5.5, 10.5.6 and 10.5.7). The members are fabricated using riveted, bolted, or welded connections. Most steel deck arches have two arch rib members, although some structures have three or more ribs (see figure 10.5.7).



Figure 10.5.5 Solid Ribbed Deck Arch



Figure 10.5.6 Braced Rib Deck Arch, New River Gorge, WV



Figure 10.5.7 Spandrel Braced Deck Arch with Six Arch Ribs

An arch with a pin at each end of the arch is called a two-hinged arch (see Figure 10.5.8). If there is also a pin at the crown, or top, of the arch, it is a three-hinged arch. Steel one-hinged and fixed arches may exist, although these are very rare. Foundation conditions, in part, dictate the requirements for hinges. Three-hinged arches, for example, are not significantly affected by small foundation settlements.

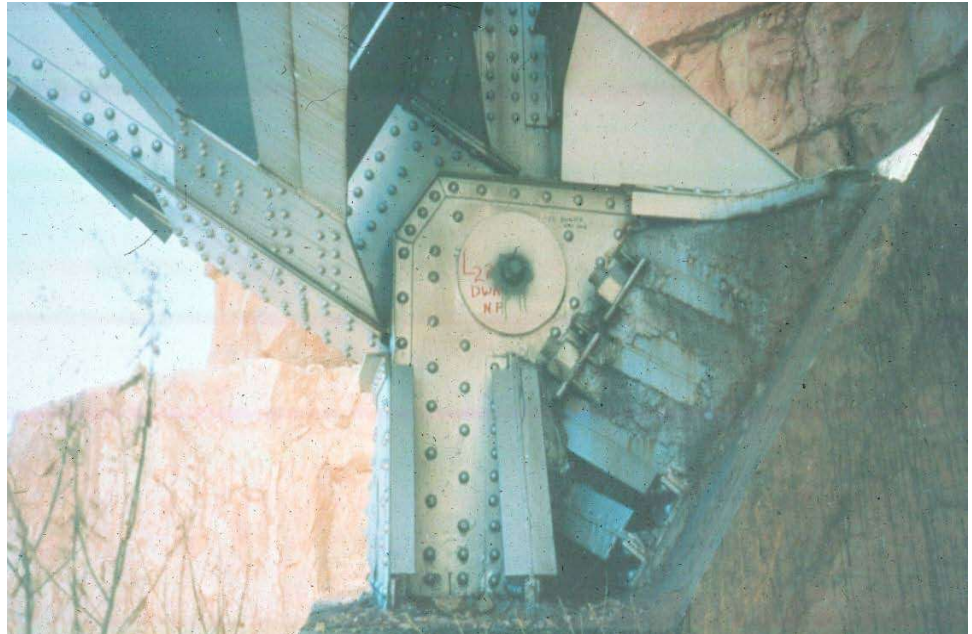

Figure 10.5.8 Hinge Pin at Skewback for Spandrel Braced Deck Arch

Primary and Secondary Members

The primary members of a deck arch bridge consist of the arches or ribs, spandrel columns or bents, spandrel girders and the floor system. The floor system consists of floorbeams and stringers (if present) (see Figure 10.5.9).

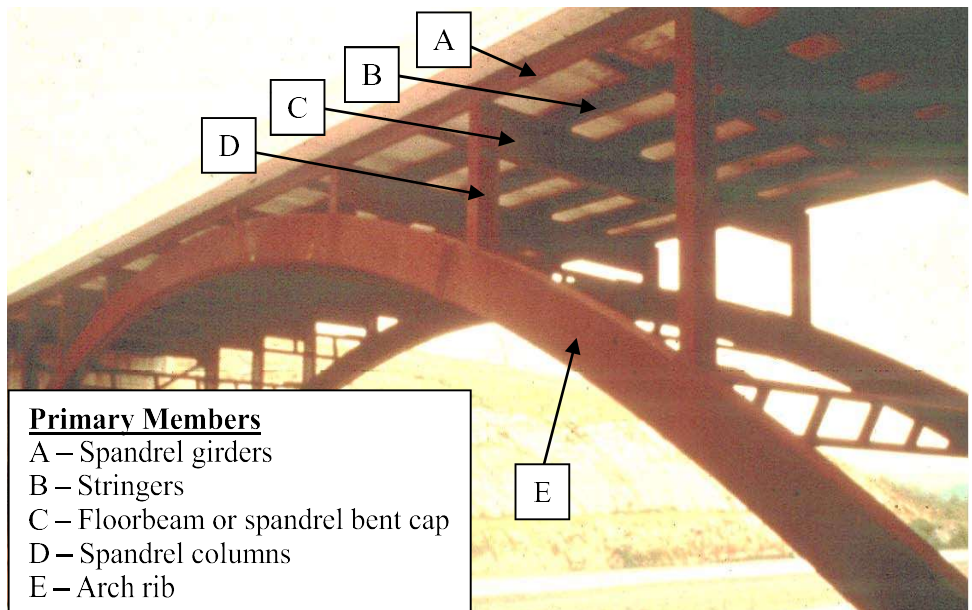

Figure 10.5.9 Solid Ribbed Deck Arch Primary Members

The secondary members of a deck arch bridge consist of the sway bracing and the upper lateral and lower lateral bracing of the arch or floor system (see Figure 10.5.10).

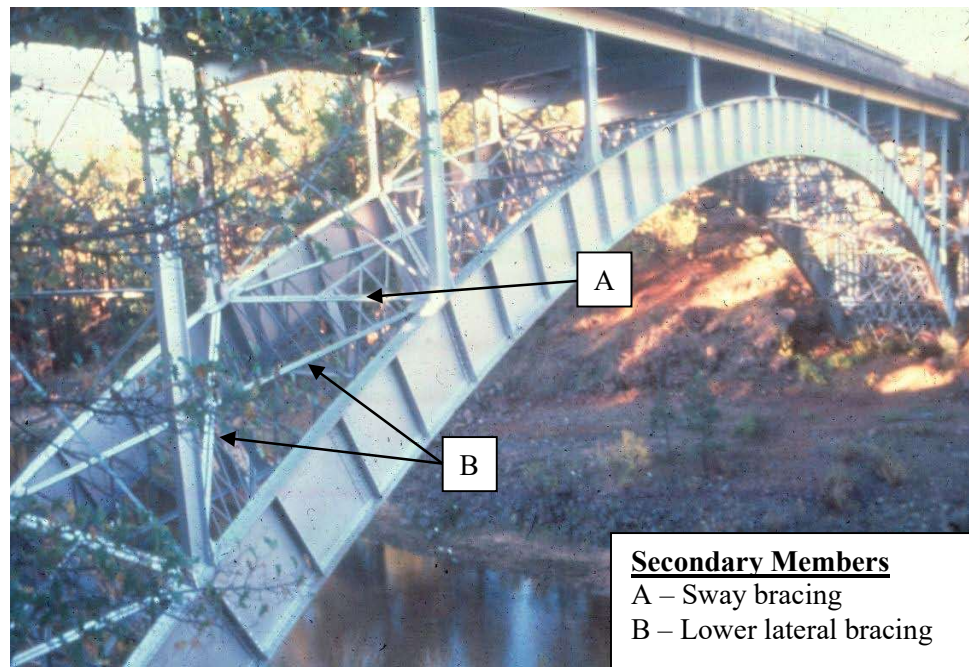

Figure 10.5.10 Solid Ribbed Deck Arch Secondary Members

Load Transfer

Traffic loads are supported by a deck. The load from the deck is transmitted to the stringers (if present) and then the floorbeams. The stringer and floorbeams resist the traffic load in bending and shear. The load is transferred to the spandrel bents and spandrel columns, which are in compression or bending. The arch supports the spandrel column and transfers the compressive load to the ground at the supports.

Fracture Critical Members

Most arches are built with two load paths (arches). However, the arch is not a tension member and is therefore not considered fracture critical.

Some members of the floor system and spandrel bent may be considered fracture critical. A floorbeam may be fracture critical if it satisfies one or more of the following conditions:

- Flexible or hinged connection to support the floorbeam connection
- Floorbeam spacing greater than 14'-0"
- No stringers supporting the deck
- Stringers are configured as simple beams

Some states consider any floorbeam to be fracture critical even if all above conditions are met.

10.5.3

Through Arch Design Characteristics

General

Through arch bridges are considered simple spans because of the basic arch function, even though many bridges of this type consist of multiple arches. Through arches are similar to deck arches and normally utilize two or three hinged systems. The arch reactions, with their massive horizontal thrusts, are diagonally oriented and transmitted to the foundations.

The steel through arch is constructed with the crown of the arch above the roadway and the arch foundations below the roadway (see Figure 10.5.11). The deck is hung from the arch by wire rope cables or eyebars.



Figure 10.5.11 Elevation View of a Braced Ribbed Through Arch

The arch members are called ribs and are usually fabricated box-type members. Steel through arches are known as either solid ribbed or braced ribbed. The solid ribbed arch, which can be any type of arch, has a single curve defining the arch shape, while the braced ribbed arch has two curves defining the arch shape, braced with truss webbing between the curves. The lower curve is the bottom rib chord, and the upper curve is the top rib chord. The rib chord bracing consists of posts and diagonals. The braced ribbed arch is sometimes referred to as a trussed arch and is more common than the solid ribbed through arch (see Figure 10.5.11).

Primary and Secondary Members

The primary members of a through arch bridge consist of arch ribs (consisting of top and bottom rib chords and rib chord bracing); rib chord bracing, hangers and floor system including floorbeams and stringers (if present) (see Figure 10.5.12).

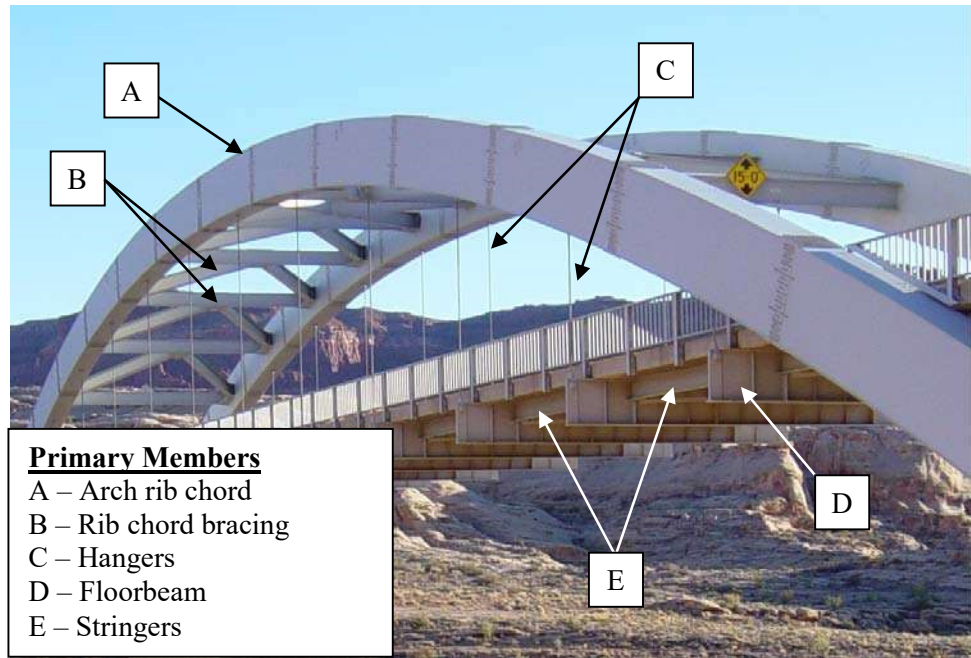

Figure 10.5.12 Through Arch Primary Members

The secondary members of a through arch bridge consist of sway bracing, lateral bracing (top and bottom rib chords and floor system) (see Figure 10.5.13).

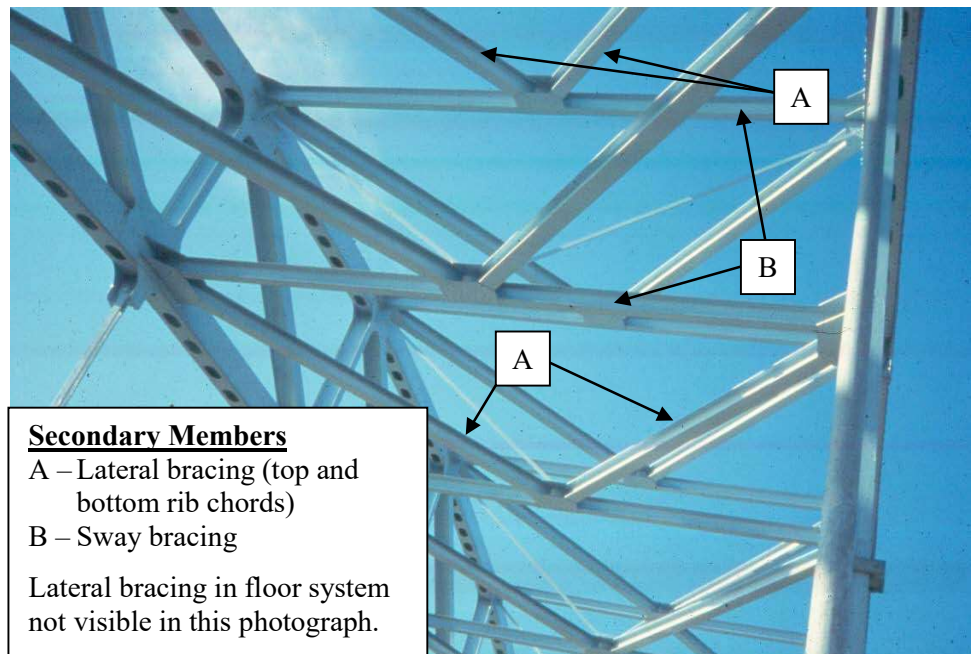

Figure 10.5.13 Through Arch Secondary Members

Load Transfer

Traffic loads are supported by a deck. The load from the deck is transmitted to the stringers (if present) and then the floorbeams. The stringer and floorbeams resist the load in bending and shear. The load is transferred to the hangers, which are in tension. Hangers can be either cables or eyebars. The arch supports the hangers and transfers the compressive load to the ground at the supports.

Fracture Critical Members

The through arch is the main load-carrying member. Since there are typically only two arch ribs, the structure is nonredundant for load path. However, the bridge is not classified as fracture critical because the arches are not tension members. The hangers may be fracture critical, depending on the results of a detailed structural analysis. Some members of the floor system may be fracture critical as described in Topic 10.5.2.

10.5.4

Tied Arch Design Characteristics

General

The tied arch is a variation of the through arch with one significant difference. In a through arch, the horizontal thrust of the arch reactions is transferred to large rock, masonry, or concrete foundations. A tied arch transfers the horizontal reactions through a horizontal tie which connects the ends of the arch together, like the string on an archer's bow (see Figure 10.5.14). The tie is a tension member. If the string of a bow is cut, the bow springs open. Similarly, if the arch tie fails, the arch loses its compression and collapses.

Design plans are generally needed to differentiate between through arches and tied arches. Another guide in correctly labeling through and tied arches is by examining the piers. Since tied arch bridges redistribute the horizontal loads to the tie girders, the piers for tie arch bridges are smaller than the piers for through arch bridges.



Figure 10.5.14 Three-Span Tied Arch Bridge

Arch members are fabricated with either solid rib members, box members or braced ribs.

The tie member is a fabricated I or box member or consists of truss members. The tie is also supported by hangers, which usually consist of wire rope cable, but can also be eyebars or built-up members.

Primary and Secondary Members

The primary members of a tied arch bridge consist of arch ribs, tie members, rib bracing truss (if present), hangers, and floor system including floorbeams and stringers (if present) (see Figure 10.5.15).

The secondary members of a tied arch bridge consist of sway bracing, lateral bracing (arch rib, top chord and floor system) (see Figure 10.5.16).

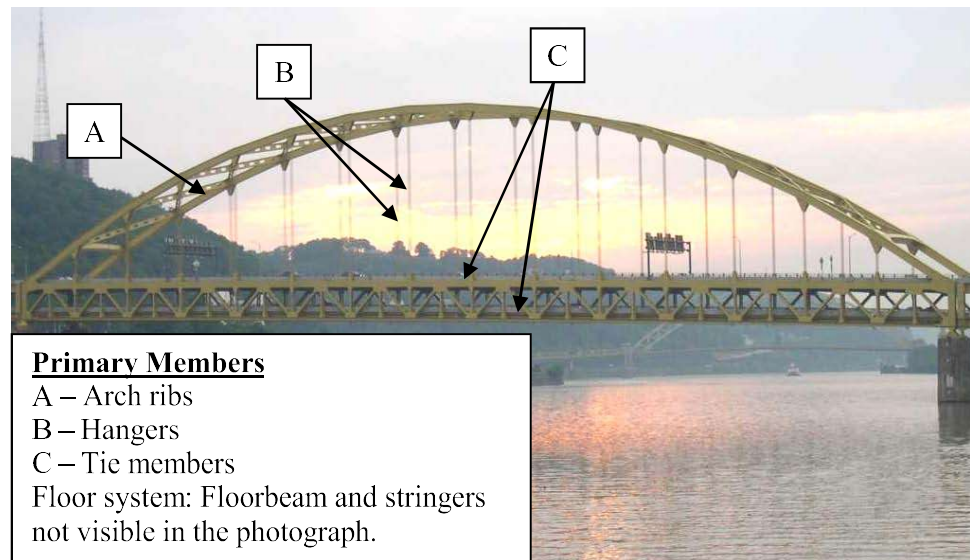

Figure 10.5.15 Tied Arch Primary Members

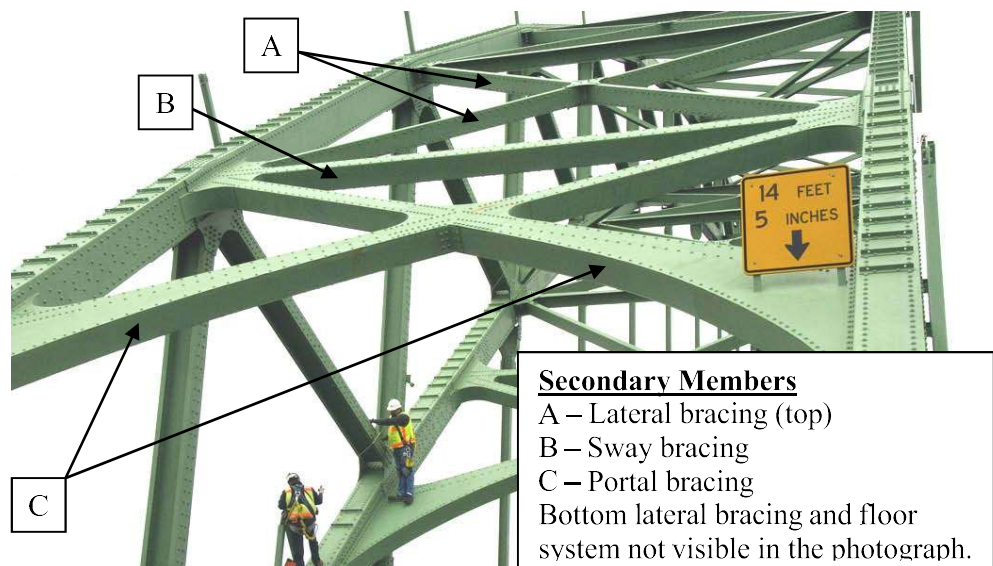

Figure 10.5.16 Tied Arch Secondary Members

Load Transfer

Traffic loads are supported by a deck. The load from the deck is transmitted to the stringers (if present) and then the floorbeams. The stringer and floorbeams resist the load in bending and shear. The load is transferred to the hangers, which are in tension. The arch supports the hangers and transfers the compressive load to the tie girder and the supports.

Fracture Critical Members

With only two load paths, arches are considered non-redundant structures. The arches are not fracture critical since they are subjected to axial compression. The tie girders, on the other hand, are axial tension members and are considered fracture critical (see Figure 10.5.17). Floor systems are similar to those discussed in Topic 10.5.2 and may be considered fracture critical.



Figure 10.5.17 Tied Arch Bridge with Fracture Critical Eyebar Tie Members

10.5.5

Overview of Common Deficiencies

Common deficiencies that occur on steel arch bridges are:

- Corrosion
- Fatigue cracking
- Overloads
- Collision damage
- Heat damage
- Coating failures

See Topic 6.3 for a detailed presentation of the properties of steel, types and causes of steel deterioration, and the examination of steel. Refer to Topic 6.4 for Fatigue and Fracture in Steel Bridges.

10.5.6

Inspection Methods and Locations

Inspection methods to determine causes of steel deterioration are discussed in detail in Topic 6.3.

Methods

Visual

The inspection of steel bridge members for deficiencies is primarily a visual activity.

Most deficiencies in steel bridges are first detected by visual inspection. In order for this to occur, a hands-on inspection, or inspection where the inspector is close enough to touch the area being inspected, is required. More exact visual observations can also be employed using a magnifying unit after cleaning the suspect area.

Physical

Removal of paint can be done using a wire brush, grinding, or sand blasting, depending on the size and location of the suspected deficiency. The use of degreasing spray before and after removal of the paint may help in revealing the deficiency.

When section loss occurs, use a wire brush, grinder or hammer to remove loose or flaked steel. After the flaked steel is removed, measure the remaining section and compare it to a similar section with no section loss.

The usual and most reliable sign of fatigue cracks is the oxide or rust stains that develop after the paint film has cracked. Experience has shown that cracks have generally propagated to a depth between one-fourth and one-half the plate thickness before the paint film is broken, permitting the oxide to form. This occurs because the paint is more flexible than the underlying steel.

Smaller cracks are not likely to be detected visually unless the paint, mill scale, and dirt are removed by carefully cleaning the suspect area. If the confirmation of a possible crack is to be conducted by another person, it is advisable not to disturb the suspected crack area so that re-examination of the actual conditions can be made.

Once the presence of a crack has been verified, examine other similar locations and details.

Advanced Inspection Methods

Several advanced methods are available for steel inspection. Nondestructive methods, described in Topic 15.3.2, include:

- Acoustic emissions testing
- Corrosion sensors
- Smart coatings
- Dye penetrant

- Magnetic particle
- Radiographic testing
- Computed tomography
- Robotic inspection
- Ultrasonic testing
- Eddy current
- Electrochemical fatigue sensor (EFS)

Other methods, described in Topic 15.3.3, include:

- Brinell hardness test
- Charpy impact test
- Chemical analysis
- Tensile strength test

Locations

When inspecting steel arch members and its floor systems (see Figure 10.5.18), it is important to check the bearing areas, shear zones, and flexure zones as described below.

Bearing Area

Examine the web areas over the supports for cracks, section loss and buckling. If bearing stiffeners, jacking stiffeners and diaphragms are present at the supports inspect them for cracks, section loss and buckling also.

Examine the bearings on each of the supports for corrosion. Check the alignment of each bearing and note any movement. Report any build up of debris surrounding the bearings that may limit the bearing from functioning properly. Check for any bearings that are frozen due to heavy corrosion. (see Topic 11.1).

Flexure Zones

Examine the entire length of the spandrel beam or girder, floorbeam and stringer between the supports. Investigate the tension and compression flanges for corrosion, loss of section, cracks, dings, scrapes and gouges. Check the flanges in high stress areas for bending or flexure-related damage. Examine the compression flange for local buckling and, although it is uncommon, for elongation or fracture of the tension flange. On continuous spans, the beams or girders over the intermediate supports have high flexural stresses due to negative moment. If welded cover plates are present, check carefully at the ends of the cover plates for cracks due to fatigue.



Figure 10.5.18 Floor System on a Through Arch

Arch Members

Arches are designed to primarily resist axial compression. Inspect the alignment of the arch and look for signs of buckling and crippling in the arch ribs (see Figure 10.5.19). Check for general corrosion and deterioration. Examine any pins for corrosion and wear. Check the arch rib splice plates and the connections at the hangers or spandrel bents.

For arch members subjected to compression, give special attention to the end posts, web members, which are vulnerable to collision damage from passing vehicles. Buckled, torn, or misaligned members may severely reduce the load carrying capacity of the member. Check for local buckling, an indication of overstress. Wrinkles or waves in the flanges, webs or cover plate are common forms of buckling.

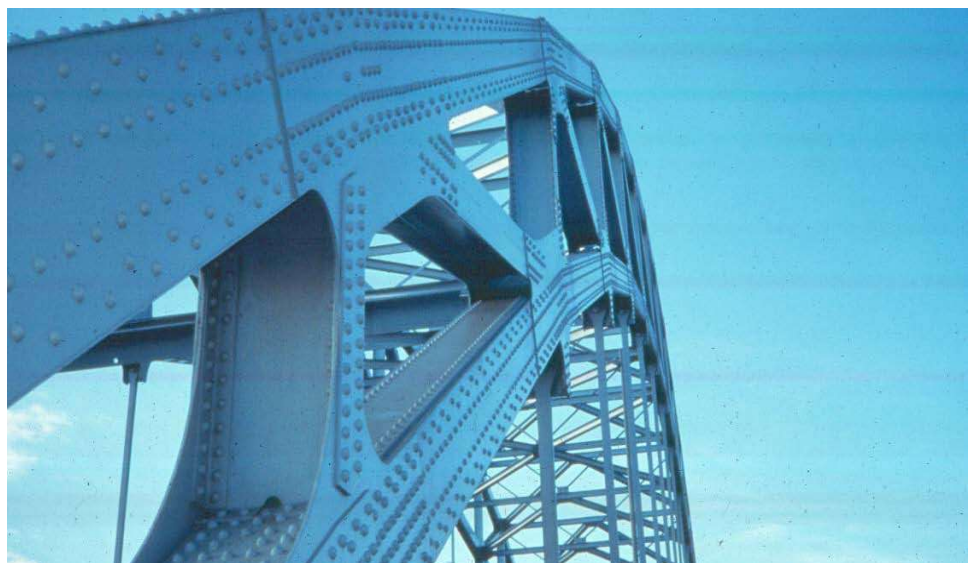

Figure 10.5.19 Through Truss Arch Members

Spandrel Members (Deck Arch)

Examine the end connections of the spandrel bents, spandrel columns and spandrel girders for cracks and loose fasteners. Check the spandrel girders and caps and columns for flexure, section loss, and buckling damage (see Figure 10.5.20). Check the bracing connections where attached to the spandrel members.



Figure 10.5.20 Braced Rib Deck Arch Showing Spandrel Columns

Hangers (Through and Tied Arches)

Hangers are designed to resist axial tensile loads and consist of either eyebars or cables. Check the connections at both ends of the hangers. Look for corrosion, cracks, and broken or misaligned wire strands. Examine the alignment of the hangers; the hangers may be near traffic, so inspect for collision or fire damage (see Figures 10.5.21 and 10.5.22). Check the hangers for any welded attachment; examine the welds between the attachment and the hanger for cracks.



Figure 10.5.21 Hanger Connection on a Through Arch



Figure 10.5.22 Performing Baseline Hardness Test on Fire Damaged Arch Cables

Gusset Plates

For arch bridges incorporating a deck, through or tied arch, gusset plates are the primary method of connecting individual arch members and vertical members together. Gusset plates may also be used to connect arch bracing members together. Thorough inspection is required for gusset plates, since these connections experience axial and shearing forces simultaneously.

For steel arches with gusset plates, give special attention to the following locations:

- Look for out-of-plane distortions particularly at areas susceptible to pack rust and along areas of unbraced length.
- Check for coating system failures, as these allow for advancement of corrosion and section loss.
- Check for corrosion and section loss, comparing current measurements to original drawings.
- Check for cracking around tack welds, bolt/riev holes, and other welds.
- Examine the gusset plate for loose or broken rivets/bolts, which can be detected through hammer sounding.
- Closely examine gusset plate retrofits, particularly welded retrofits as they are very problematic.

Refer to Topic 10.8.4 for detailed information on inspection locations and methods for gusset plates.

Tied Arches and Tie Girders

In tied arch bridges, axial compressive forces from the arch members are transferred into the tie girder. The tie girder resists axial tension. For tension members, inspect the following locations:

- Check for section loss (corrosion) and cracks.
- For box-shaped chord members, check inside for debris and corrosion, cracks or section loss.
- Examine eyebar heads for cracks in the eyes and in the forge zone.
- Check loop rods for cracking where the loop is formed.
- Where multiple eyebars make one member, check the tension is evenly distributed - each eyebar element perfectly parallel and evenly spaced to the adjacent elements.
- Check eyebars or loop rods where attachments are welded to them, especially if such attachments connect the eyebars together.
- Determine whether the spacers on the pins are holding the eyebars and loop rods in their proper positions.
- Look for repairs, especially welded repairs, if they have been applied to steel tension members. Base metal cracks can easily develop at these locations.
- Check the alignment of the members, make sure they are straight and not bowed - this could be a sign of pier movement, collision damage or

unintentional force reversal.

- Check the girders for welded attachments.

Check floorbeam-to-tie member connections for distortion caused by fatigue or horizontal floorbeam displacement in the webs of the floorbeams when the stringers are placed above the floorbeams.

Problematic Details

Problematic details checked for deficiencies and deterioration include:

- Triaxial constraint
- Intersecting welds
- Cover plates
- Cantilevered suspended spans
- Insert plates
- Field welds: patch and splice plates
- Intermittent welds
- Out-of-plane bending
- Pin-and-hanger assemblies
- Back-up bars
- Mechanical fasteners and tack welds

Note that out-of-plane bending may occur at the following areas, which are presented further in Topic 6.4.8:

- Girder web connections for diaphragms and floorbeams, including connections plates at the top flange, connection plates at the bottom flange, and connection plates at the bottom flange for skewed bridges
- Lateral bracing gussets and diaphragm connection plates
- Diaphragm connections to gusset plates
- Cantilevered floorbeams

In addition to the common problematic details, arches also utilize the following:

- Stiffeners (transverse or longitudinal)
- Groove welded butt splices
- Lateral bracing gusset plates
- Web-to-flange welds
- Miscellaneous connections (railing or utilities)

See Topic 6.4.8 for additional information on problematic details.

Secondary Members

Investigate the alignment of the bracing elements (see Figure 10.5.25). Check horizontal connection plates, which can trap debris and moisture and are susceptible to a high degree of corrosion and deterioration. Examine the diaphragm and bracing connections for loose fasteners or cracked welds. This problem is most common on skewed bridges, and it has also been observed on bridges with a high frequency of combination truck loads. Check for distorted members. Distorted secondary members may be an indication the primary members may be overstressed or the substructure may be experiencing differential settlement. Examine the end connections for cracks, corrosion, and loose fasteners.

Misalignment of secondary members may be an indication of differential structure movement or substructure settlement.



Figure 10.5.23 Bracing Members in Deck Arch Bridge

Areas Exposed to Traffic

Inspect any areas exposed to traffic for collision damage (see Figure 10.5.26). If collision damage is found, document the location and dimensions and reference with photographs and/or sketches.



Figure 10.5.24 Through Arch Member Exposed to Traffic

Areas Exposed to Drainage

Check horizontal surfaces that can trap debris and moisture and are susceptible to a high degree of corrosion and deterioration. Areas that trap water and debris can result in active corrosion cells and excessive loss in section. This can result in notches susceptible to fatigue or perforation and loss of section.

On steel arch bridges check:

- Areas exposed to drainage runoff
- Lateral bracing gusset plates
- Inside built-up arch members
- Pockets created by floor system connections
- Tightly packed panel points
- Pin-and-hanger and cable assemblies
- Bottom flanges of arch members and floor system

10.5.7

Evaluation

State and Federal rating guideline systems have been developed to aid in the inspection of steel superstructures. The two major rating guideline systems currently in use are the FHWA's *Recording and Coding Guide for the Structural Inventory and Appraisal of the Nation's Bridges* used for the National Bridge Inventory (NBI) component rating method and the AASHTO *Guide Manual for Bridge Element Inspection* for element level condition state assessment.

NBI Component Condition Rating Guidelines

Using NBI component condition rating guidelines, a one-digit code on the Federal Structure Inventory and Appraisal (SI&A) sheet indicates the condition of the superstructure. Rating codes range from 9 to 0 where 9 is the best rating possible. See Topic 4.2 (Item 59) for additional details about NBI component condition rating guidelines.

Consider previous inspection data along with current inspection findings to determine the correct rating.

Element Level Condition State Assessment

In an element level condition state assessment of a steel arch bridge, possible AASHTO National Bridge Elements (NBEs) and Bridge Management Elements (BMEs) are:

<u>NBE No.</u>	<u>Description</u>
Superstructure	
102	Steel Closed Web/Box Girder
107	Steel Girder/Beam
113	Steel Stringer
141	Steel Arch
148	Steel Cable
152	Steel Floor Beam
161	Steel Pin, Pin-and-Hanger Assembly, or both
162	Steel Gusset Plate

<u>BME No.</u>	<u>Description</u>
Wearing Surfaces and Protection Systems	
515	Steel Protective Coating

The unit quantity for the closed web/box girder, girder/beam, stringer, arch, cable, floor beam, and pier cap is feet. The total length is distributed among the four available condition states depending on the extent and severity of the deficiency. The unit quantity for the pin-and-hanger assembly and gusset plate is each, with each pin-and-hanger element placed in one of the four available condition states depending on the extent and severity of the deficiency. The sum of all condition states equals the total quantity of the National Bridge Element or Bridge Management Element. Condition State 1 is the best possible rating. See the *AASHTO Guide Manual for Bridge Element Inspection* for condition state descriptions. For pin-and-hanger assemblies, see Topic 10.7. For gusset plates, see Topic 10.8.

The following Defect Flags are applicable in the evaluation of steel arch systems:

<u>Defect Flag No.</u>	<u>Description</u>
356	Steel Cracking/Fatigue
357	Pack Rust
362	Superstructure Traffic Impact (load capacity)
363	Steel Section Loss
364	Steel out-of-plane (Compression Member)

See the AASHTO *Guide Manual for Bridge Element Inspection* for the application of Defect Flags.

Table of Contents

Chapter 10 Inspection and Evaluation of Steel Superstructures

10.6	Steel Rigid Frames.....	10.6.1
10.6.1	Introduction.....	10.6.1
10.6.2	Design Characteristics.....	10.6.1
	General	10.6.1
	K-Frames	10.6.2
	Delta Frames	10.6.3
	Stiffeners	10.6.4
	Transverse Stiffeners	10.6.4
	Longitudinal Stiffeners	10.6.4
	Radial Stiffeners.....	10.6.4
	Floor System Arrangement.....	10.6.6
	Multiple Frame System.....	10.6.6
	Frame-Floorbeam System.....	10.6.6
	Frame-Floorbeam-Stringer System.....	10.6.6
	Primary and Secondary Members	10.6.7
	Stress Zones.....	10.6.8
	Fracture Critical Members.....	10.6.9
10.6.3	Overview of Common Deficiencies.....	10.6.10
10.6.4	Inspection Methods and Locations	10.6.10
	Methods.....	10.6.10
	Visual.....	10.6.10
	Physical.....	10.6.10
	Advanced Inspection Methods.....	10.6.11
	Locations	10.6.11
	Bearing Areas.....	10.6.11
	Shear Zones.....	10.6.12
	Flexure Zones.....	10.6.12
	Gusset Plates	10.6.13
	Problematic Details.....	10.6.13
	Secondary Members.....	10.6.14
	Areas Exposed Drainage.....	10.6.14
	Areas Exposed to Traffic	10.6.14
10.6.5	Evaluation	10.6.15
	NBI Component Condition Rating Guidelines.....	10.6.15
	Element Level Condition State Assessment.....	10.6.15

This page is intentionally left blank.

Topic 10.6 Steel Rigid Frames

10.6.1

Introduction

A frame consists of horizontal members rigidly attached to vertical or inclined members without the use of bearings (see Figure 10.6.1). Steel rigid frames are popular today in building construction because of their space-saving characteristics and aesthetics. The same principles that permit the omission of intermediate column supports in buildings are applied to bridge frames. In a steel rigid frame bridge structure, the frame sides or “legs” replace intermediate supports. Because the legs contribute to the structures overall capacity, increased span lengths and material savings can be realized.



Figure 10.6.1 Typical Rigid K-frame Constructed of Two Frames

10.6.2

Design Characteristics

General

Frames are not referred to as having a single, simple, multiple, or continuous spans. Also, steel rigid frame structures are used only in straight horizontal applications.

Steel rigid frame bridges typically consist of welded plate girder construction with bolted field splices in low stress areas and welded stiffeners in high stress areas. The frames are spaced from about 7 to 20 feet on centers, depending on loads, span lengths, and type of floor system. Steel rigid frames can be economical for spans from 50 feet to over 200 feet. Standard abutments and expansion bearings support the ends of the frame girders.

The superstructure of a rigid frame bridge can be constructed of two frames similar to a two-girder bridge (see Figure 10.6.1) or of multiple frames in the same manner as a multi-girder bridge (see Figure 10.6.2). These frames can be thought

of as fabricated girders with attached legs.



Figure 10.6.2 Typical Rigid Frame Constructed of Multiple Frames

K – Frames

Most steel rigid frame bridges are multi-span structures and are commonly referred to as "K-frame" or "grasshopper leg" bridges (see Figure 10.6.1). The sloping legs give the rigid frame a "K" shape, when looked at by rotating the frame counterclockwise 90 degrees. K-frames are not economical for very short or very long span bridges. Because of their aesthetically pleasing appearance, sometimes an effort is made to use steel rigid frames whenever possible.

It is possible to think that the legs of the K-frame look very much like piers and consider them part of the substructure. This is not the case because there is no bearing between the legs and the girder portion of the frame (see Figure 10.6.3).

Since there are no bearings between the legs and girder portion of the frame, bending forces are transferred between the girder portion and the legs (see Figure 10.6.3).



Figure 10.6.3 Connection Between Legs and Girder Portion

Delta Frames

In some designs, a triangular frame configuration can be used. For very long spans, two K-frames can be connected together end-to-end (see Figure 10.6.4). Instead of one of the end spans bearing on an abutment, it is connected to the end span of another K-frame. The bottoms of the legs are also connected together and share the same bearing. This type of configuration is known as a delta frame. The leg connections form an inverted triangle with the girder portion of the frame. The Greek letter Delta (∇) is the symbol used for this triangle.

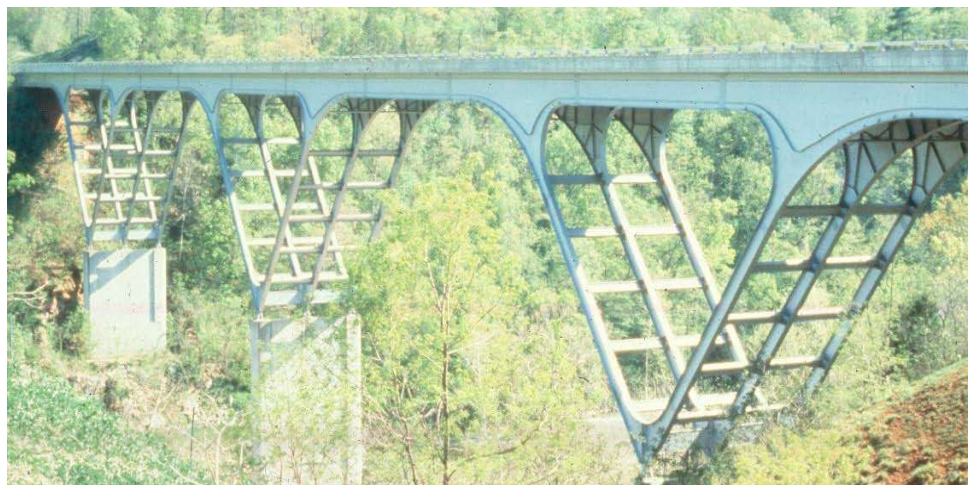

Figure 10.6.4 Delta Frame

Regardless of the frame configuration, the entire portion of the bridge, (legs and girders) constitutes the frame, and is considered the superstructure. The legs of rigid frames are supported by relatively small concrete footings and bearings which are essentially hinges (see Figure 10.6.5).



Figure 10.6.5 Bearings

Stiffeners

Steel rigid frames may have up to three different types of stiffeners (see Figure 10.6.6).

Transverse Stiffeners

Transverse stiffeners are placed approximately perpendicular to the flanges and welded to the web and flanges of the frame at spacings required by design. Transverse stiffeners are used to prevent buckling in high shear regions.

Longitudinal Stiffeners

Longitudinal stiffeners are placed parallel to the flanges and welded to the web of the frame. They may extend the entire length of the frame girder or just in areas of high moment. Longitudinal stiffeners resist web buckling in the compression zone and therefore are closer to the top flange in areas of higher positive moment and closer to the bottom flange in areas of higher negative moment.

Radial Stiffeners

Radial stiffeners are placed perpendicular along the frame knee bottom flange radius. The radial stiffeners are welded to the flange and web at spacings required by design. This type of stiffener is used to resist shear and moment forces in the knee.

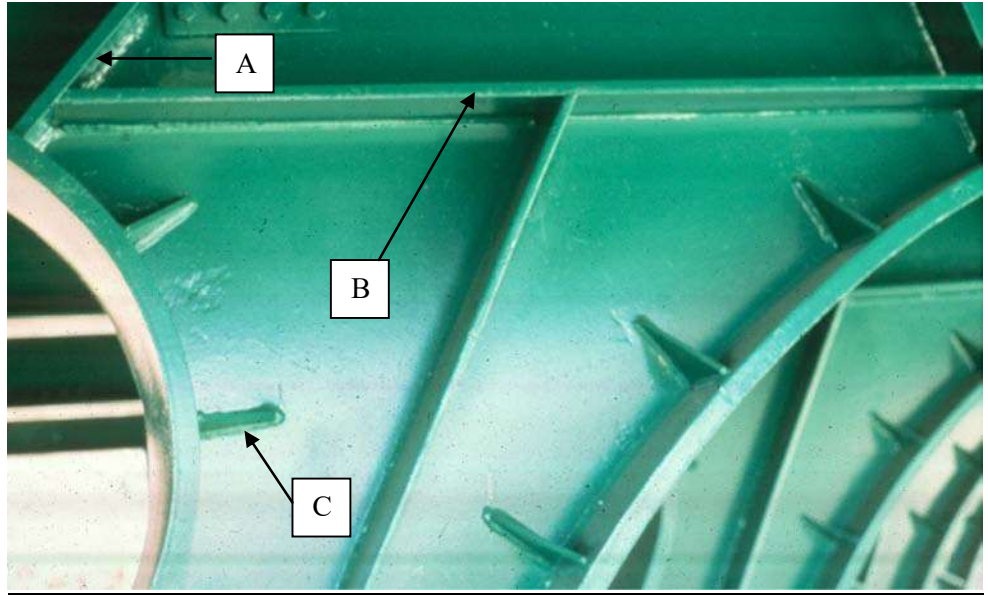

Stiffeners

- A – Transverse
- B – Longitudinal
- C – Radial

Figure 10.6.6 Transverse, Longitudinal, and Radial Stiffeners on a Frame Knee

Floor System Arrangement

A rigid frame has one of three floor systems:

Multiple Frame System

For a multiple frame system, the deck is supported only by the frames.

Frame-Floorbeam System

Floorbeams are connected to the girder portion of the two frames. The floorbeams are much smaller than the girder portion of the frame and are perpendicular to the flow of traffic. The deck is supported by the floorbeams, which in turn transmit the loads to the frames. The floorbeams can be either rolled beams, fabricated girders, or fabricated cross frames.

Frame-Floorbeam-Stringer System

Longitudinal stringers, parallel to the frames, are connected to the floorbeams (see Figure 10.6.7). Floorbeams are connected to the girder portion of the two frames. The stringers are typically rolled sections and are supported by the floorbeams.

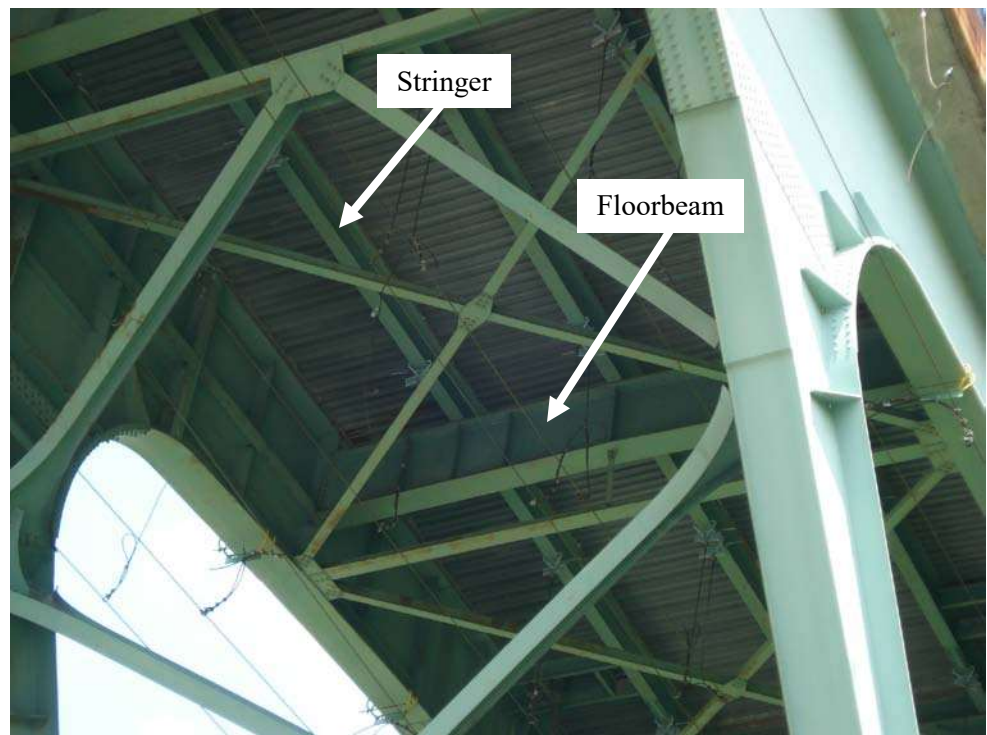

Figure 10.6.7 Two Frame Bridge with Floorbeam-Stringer Floor System

Primary and Secondary Members

For steel rigid frame bridges, the primary members are the frames as a whole, including floorbeams and stringers (if present) (see Figure 10.6.7). However, for ease of discussion, the frame is commonly broken down into the following five elements:

- Frame girder - the horizontal sections
- Frame leg - the inclined sections
- Frame knee - the intersection between the frame girder and frame leg
- Floorbeams (if present)
- Stringers (if present)

Secondary members consist of lateral bracing, sway bracing and diaphragms.

In a two frame system, lateral bracing members are placed diagonally between the horizontal members of the frames. This bracing restricts any horizontal differential and longitudinal movements between the frames. This bracing is in the plane of the bottom flange of the girder portion of the frame or between the legs of the frame (see Figure 10.6.8).

In a two frame system, sway bracing is placed between the leg portions of the frame (see Figure 10.6.8). In a multiple frame system diaphragms are placed perpendicular between the frames. The sway bracing and diaphragms minimize any transverse movements of the frames (see Figure 10.6.9).

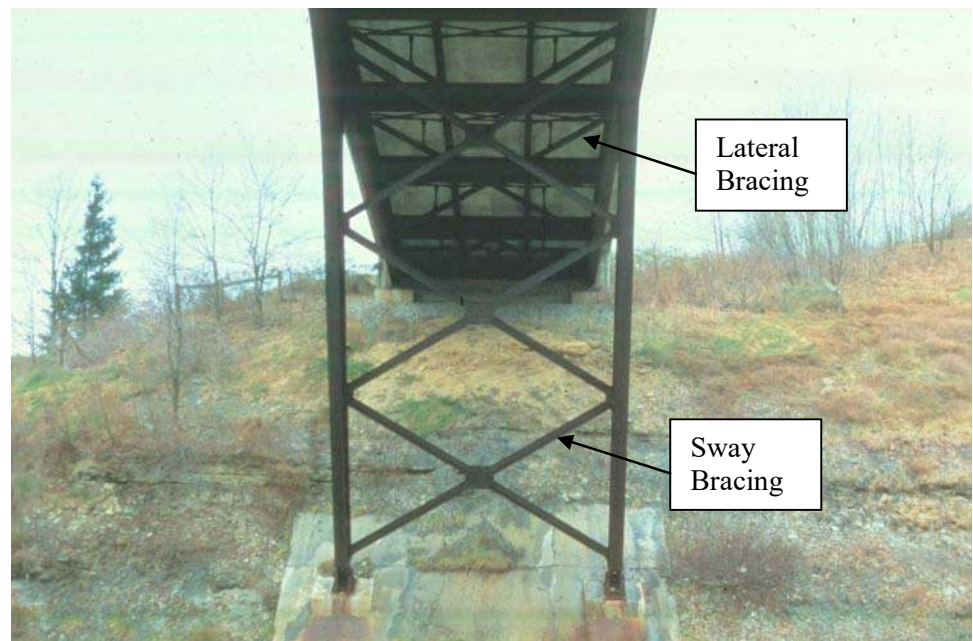

Figure 10.6.8 Lateral and Sway Bracing for the Frame Legs

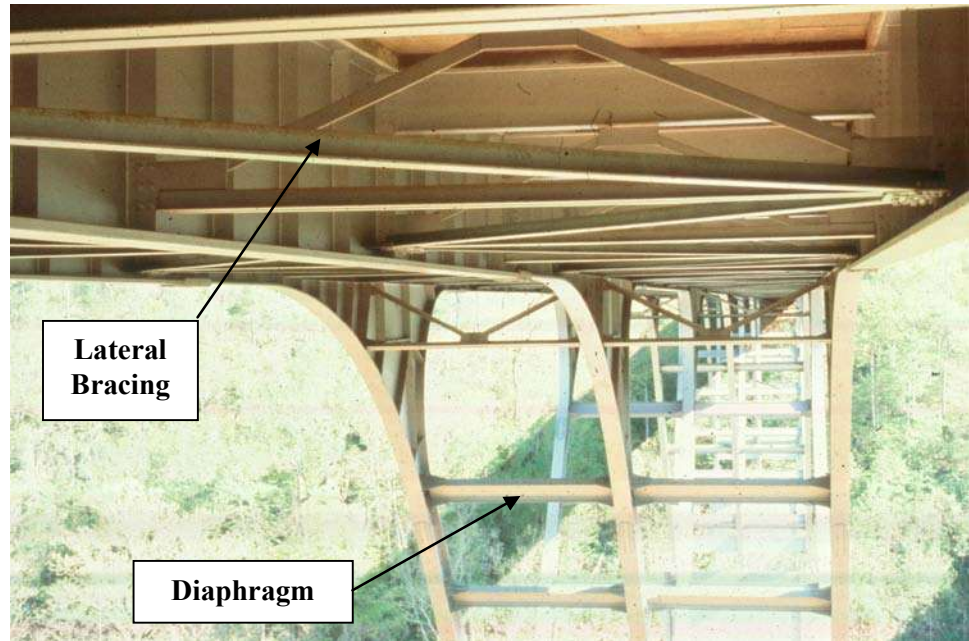
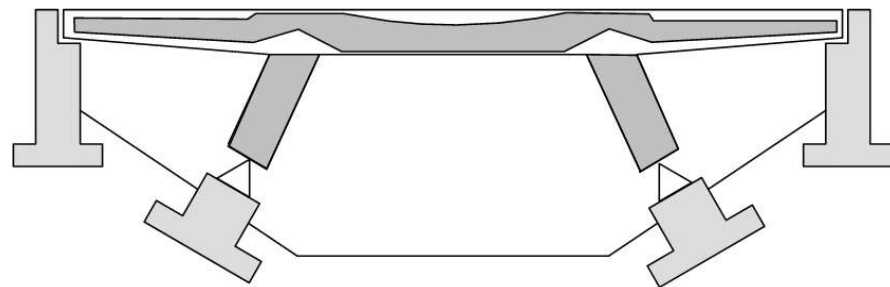

Figure 10.6.9 Lateral Bracing and Diaphragms

Stress Zones

Each element of the frame resists various levels of stress due to moment and shear. Tension zones are similar to those for concrete rigid frames (see Figure 10.6.10).

Stress zones for the floor systems are similar to the two-girder floor systems discussed in Topic 10.2.





Tension Zones 
Compression Zones 
Shear Zones **Highest at frame knee and substructure supports**

Figure 10.6.10 Stress Zones in a Frame

Fracture Critical Members

A rigid frame consisting of two frames has no load path redundancy. This means that a two frame steel rigid frame is considered a fracture critical bridge type (see Figure 10.6.11). Potential fracture critical members include portions of the frames in tension, as well as floorbeams (if applicable).



Figure 10.6.11 Fracture Critical Structure - No Load Path Redundancy

A rigid frame bridge consisting of three or more frames has load path redundancy and is not considered fracture critical (see Figure 10.6.12).



Figure 10.6.12 Multiple Frame Rigid Frame – Not a Fracture Critical Structure

10.6.3

Overview of Common Deficiencies

Common deficiencies that occur on steel rigid frame bridges include:

- Corrosion
- Fatigue cracking
- Overloads
- Collision damage
- Heat damage
- Coating failures

See Topic 6.3 for a detailed presentation of the properties of steel, types and causes of steel deterioration, and the examination of steel. Refer to Topic 6.4 for Fatigue and Fracture in Steel Bridges.

10.6.4

Inspection Methods and Locations

Inspection methods to determine other causes of steel deterioration are discussed in detail in Topic 6.3.

Methods

Visual

The inspection of steel bridge members for deficiencies is primarily a visual activity.

Most deficiencies in steel bridges are first detected by visual inspection. In order for this to occur, a hands-on inspection, or inspection where the inspector is close enough to touch the area being inspected, is required. More exact visual observations can also be employed using a magnifying unit after cleaning the suspect area.

Physical

Removal of paint can be done using a wire brush, grinding, or sand blasting, depending on the size of the suspected deficiency. The use of degreasing spray before and after removal of the paint may help in revealing the deficiency.

When section loss occurs, use a wire brush, grinder or hammer to remove loose or flaked steel. After the flaked steel is removed, measure the remaining section and compare it to a similar section with no section loss.

The usual and most reliable sign of fatigue cracks is the oxide or rust stains that develop after the paint film has cracked. Experience has shown that cracks have generally propagated to a depth between one-fourth and one-half the plate thickness before the paint film is broken, permitting the oxide to form. This occurs because the paint is more flexible than the underlying steel.

Smaller cracks are not likely to be detected visually unless the paint, mill scale, and dirt are removed by carefully cleaning the suspect area. If the confirmation of a possible crack is to be conducted by another person, it is advisable not to disturb the suspected crack area so that re-examination of the actual conditions can be made.

Once the presence of a crack has been verified, examine other similar locations and details.

Advanced Inspection Methods

Several advanced methods are available for steel inspection. Nondestructive methods, described in Topic 15.3.2, include:

- Acoustic emissions testing
- Corrosion sensors
- Smart coatings
- Dye penetrant
- Magnetic particle
- Radiographic testing
- Computed tomography
- Robotic inspection
- Ultrasonic testing
- Eddy current
- Electrochemical fatigue sensor (EFS) (Detects fatigue growth)

Other methods, described in Topic 15.3.3, include:

- Brinell hardness test
- Charpy impact test
- Chemical analysis
- Tensile strength test

Locations

Bearing Areas

Examine the floor system, frame knee area and the web areas over the supports for cracks, section loss or buckling. If bearing stiffeners, jacking stiffeners and diaphragms are present at the supports inspect them for cracks, section loss and buckling also.

Examine the bearings at each support for corrosion. Check the alignment of each bearing and note any movement. Report any build up of debris surrounding the bearings that may limit the bearing from functioning properly. Check for any bearings that are frozen due to heavy corrosion (see figure 10.6.13). See Topic 11.1 for a detailed presentation on the inspection of bearings.



Figure 10.6.13 Bearing Area of a Two Frame Bridge

Shear Zones

Examine the web area of the girder portion near the bearings and knee areas for section loss due to corrosion. Check the web area of the girder portion near the bearings and knee areas for buckling. Inspect floorbeams and stringers (if present) near their respective bearing areas for corrosion or buckling. Check the bottom of the frame legs for corrosion or buckling.

Flexure Zones

Check the tension and compression flanges for corrosion, section loss, cracks or buckling. Give special attention to the flanges at the connection between the legs and girder portion of the beam. Bending moment is at its greatest in this area (see Figure 10.6.14).

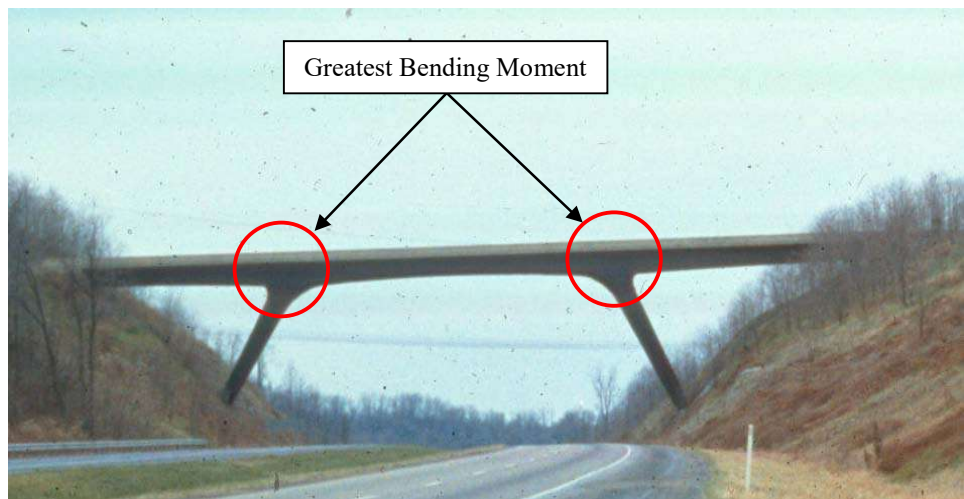

Figure 10.6.14 Flexural Zones (Greatest Bending Moment)

Gusset Plates

Gusset plates may be used to connect frame bracing members together. Thorough inspection is required for gusset plates, since these connections experience axial and shearing forces simultaneously.

For steel frames with gusset plates, give special attention to the following locations:

- Look for out-of-plane distortions particularly at areas susceptible to pack rust and along areas of unbraced length.
- Check for coating system failures, as these allow for advancement of corrosion and section loss.
- Check for corrosion and section loss, comparing current measurements to original drawings.
- Check for cracking around tack welds, bolt/rivet holes, and other welds.
- Examine the gusset plate for loose or broken rivets/bolts, which can be detected through hammer sounding.
- Closely examine gusset plate retrofits, particularly welded retrofits as they are very problematic.

Refer to Topic 10.8.4 for detailed information on inspection locations and methods for gusset plates.

Problematic Details

Problematic details checked for deficiencies and deterioration include:

- Triaxial constraint
- Intersecting welds
- Cover plates
- Cantilevered suspended spans
- Insert plates
- Field welds: patch and splice plates
- Intermittent welds
- Out-of-plane bending
- Pin-and-hanger assemblies
- Back-up bars
- Mechanical fasteners and tack welds

Note that out-of-plane bending may occur at the following areas, which are presented further in Topic 6.4.8:

- Girder web connections for diaphragms and floorbeams, including connections plates at the top flange, connection plates at the bottom flange, and connection plates at the bottom flange for skewed bridges
- Lateral bracing gussets and diaphragm connection plates

- Diaphragm connections to gusset plates
- Cantilevered floorbeams

In addition to the common problematic details, rigid frames also utilize the following:

- Stiffeners (transverse or longitudinal)
- Groove welded butt splices
- Lateral bracing gusset plates
- Web-to-flange welds
- Miscellaneous connections (railing or utilities)

See Topic 6.4.8 for additional information on problematic details.

Secondary Members

Check horizontal connection plates which can trap debris and moisture and are susceptible to a high degree of corrosion and deterioration. Investigate the areas beneath drainpipes and deck joints for corrosion from exposure to roadway drainage. Examine the connection areas of the lateral bracing or diaphragms for cracked welds, fatigue cracks, and loose fasteners. Check for distortion in the secondary members. Distorted secondary members may be an indication the primary members are overstressed or the substructure may be experiencing differential settlement.

Areas Exposed to Drainage

The areas that trap water and debris result in active corrosion cells and can cause notches susceptible to fatigue or perforation and loss of section.

On rigid frame bridges check:

- Horizontal surfaces that include top of bottom flange
- Lateral bracing gusset plates
- Pockets created by floor system connections

Areas Exposed to Traffic

Check underneath the bridge for collision damage to the frame sections and bracing if the bridge crosses over a highway, railway, or navigable channel. Document any cracks, section loss, scrapes or distortion found.

10.6.5

Evaluation

State and Federal rating guideline systems have been developed to aid in the inspection of steel superstructures. The two major rating guideline systems currently in use are the FHWA's *Recording and Coding Guide for the Structural Inventory and Appraisal of the Nation's Bridges* used for the National Bridge Inventory (NBI) component condition rating method and the *AASHTO Guide Manual for Bridge Element Inspection* for element level condition state assessment.

NBI Component Condition Rating Guidelines

Using NBI component condition rating guidelines, a one-digit code on the Federal Structure Inventory and Appraisal (SI&A) sheet indicates the condition of the superstructure. Component condition rating codes range from 9 to 0 where 9 is the best rating possible. See Topic 4.2 (Item 59) for additional details about NBIS component condition rating guidelines.

Consider the previous inspection data along with current inspection findings to determine the correct component condition rating.

Element Level Condition State Assessment

The element level method does not have specific elements for steel rigid frames. Due to this fact, individual states may choose to create their own elements or use the AASHTO National Bridge Elements (NBEs) or Bridge Management Elements (BMEs) that “best describe” the rigid frame. In an element level condition state assessment of a steel rigid frame bridge, possible AASHTO National Bridge Elements or Bridge Management Elements that relate closest to a rigid frame include:

<u>NBE No.</u>	<u>Description</u>
Superstructure	
107	Steel Girder/Beam
113	Steel Stringer
152	Steel Floor Beam
162	Steel Gusset Plate

<u>BME No.</u>	<u>Description</u>
Wearing Surfaces and Protection Systems	
515	Steel Protective Coating

The unit quantity for the girders/beams, stringers, and floorbeams is feet. The total length is distributed among the four available condition states depending on the extent and severity of the deficiency. The unit quantity for gusset plates (if applicable) is each, with each gusset plate element placed in one of the four available condition states depending on the extent and severity of the deficiency. The unit quantity for protective coating is square feet, with the total area distributed among the four available condition states depending on the extent and severity of the deficiency. The sum of all condition states equals the total quantity of the National Bridge Element or Bridge Management Element. Condition State 1 is the best possible rating. See the *AASHTO Guide Manual for Bridge Element*

Inspection for condition state descriptions. For gusset plates, see Topic 10.8.

For states that create their own Agency Developed Elements, use that particular state's bridge inspection manual to determine the appropriate element(s) as well as the correct condition state(s).

The following Defect Flags are applicable in the evaluation of steel rigid frames:

<u>Defect Flag No.</u>	<u>Description</u>
356	Steel Cracking/Fatigue
357	Pack Rust
362	Superstructure Traffic Impact (load capacity)
363	Steel Section Loss
364	Steel out-of-plane (Compression Member)

See the AASHTO *Guide Manual for Bridge Element Inspection* for the application of Defect Flags.

Table of Contents

Chapter 10 Inspection and Evaluation of Steel Superstructures

10.7	Pin and Hanger Assemblies	10.7.1
10.7.1	Introduction.....	10.7.1
10.7.2	Design Characteristics.....	10.7.3
	Primary and Secondary Members	10.7.3
	Forces in a Pin – Design vs. Actual.....	10.7.8
	Fracture Critical Pin-and-Hanger Assemblies.....	10.7.10
10.7.3	Overview of Common Deficiencies.....	10.7.11
10.7.4	Inspection Methods and Locations	10.7.12
	Methods	10.7.12
	Visual	10.7.12
	Physical	10.7.12
	Advanced Inspection Methods.....	10.7.12
	Locations	10.7.14
	General	10.7.14
	Hangers	10.7.16
	Problematic Areas	10.7.18
	Pins.....	10.7.19
	Retrofits	10.7.20
10.7.5	Evaluation	10.7.22
	NBI Component Condition Rating Guidelines.....	10.7.22
	Element Level Condition State Assessment.....	10.7.22

This page intentionally left blank

Topic 10.7 Pin-and-Hanger Assemblies

10.7.1

Introduction

Pin-and-hanger assemblies are devices that utilize two pins with connecting hangers in bridges to permit longitudinal expansion movement and rotation (see Figure 10.7.1). If only rotation of the joint is desired, one pin is used (see Figure 10.7.2).

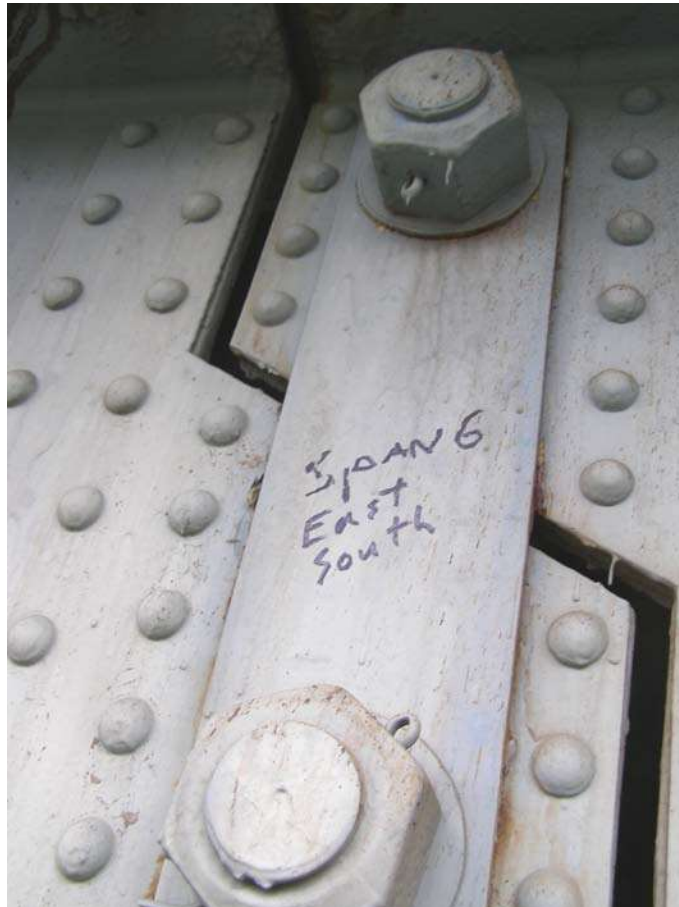

Figure 10.7.1 Typical Pin-and-Hanger Assembly

Pin-and-hanger joints are usually found in multi-span bridges designed prior to 1970. Incorporating a hinge in a structure simplifies analysis. It also moves expansion joints (and drainage related damage) away from the bearings, abutments and piers (see Figure 10.7.3).

Modern design techniques and computer programs enable the engineer to design multi-span bridges without hinges. The problems associated with pin-and-hanger details far outweigh the advantages of placing expansion joints away from substructure units.

Although pin-and-hanger designs are no longer used, many bridges with these assemblies are still in service and will remain for the foreseeable future. Therefore, it is very important to pay special attention to these details during inspection.



Figure 10.7.2 Single Pin with Riveted Pin Plate



Figure 10.7.3 Pin-and-Hanger Assembly Locations Relative to Piers

10.7.2

Design Characteristics

Primary and Secondary Members

There are many different components to a pin-and-hanger assembly as Figure 10.7.4 demonstrates.

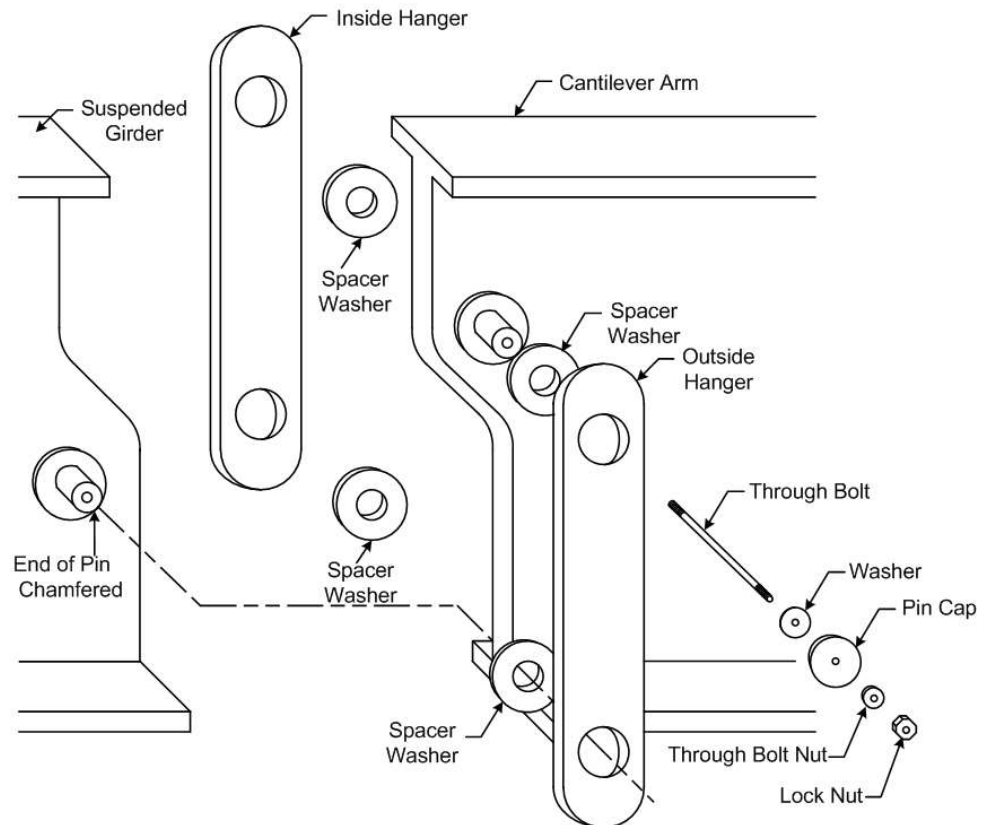

Figure 10.7.4 Pin-and-Hanger Assembly

The primary members of a pin-and-hanger assembly are the pin and the hanger link. The pin may be drilled to accept a through-bolt (see Figure 10.7.5) or threaded to accept a large nut (see Figure 10.7.6). Threaded pins are often stepped (or shouldered) to accept a small diameter nut. The hanger link may be a plain flat plate with two holes or an eyebar shaped plate (see Figure 10.7.7).

The secondary members of a pin-and-hanger assembly include through-bolts and the pin cap (see Figure 10.7.8), nuts (see Figure 10.7.9), cotter pins on small assemblies with pins less than 4 inches in diameter, spacer washers and doubler plates which reinforce the beam web around the pin hole (see Figure 10.7.10).

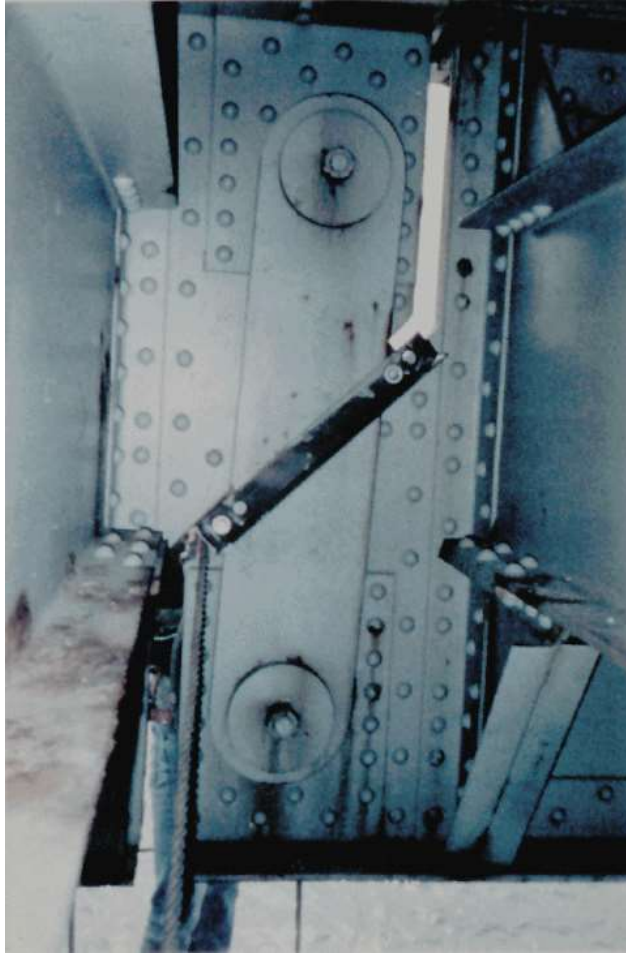

Figure 10.7.5 Pin Cap with Through Bolt

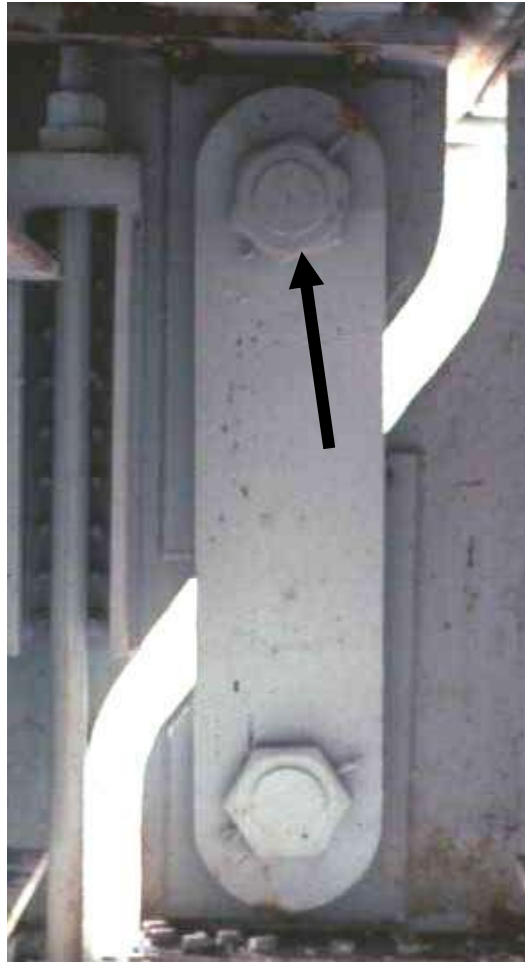

Figure 10.7.6 Threaded Pin with Retaining Nut

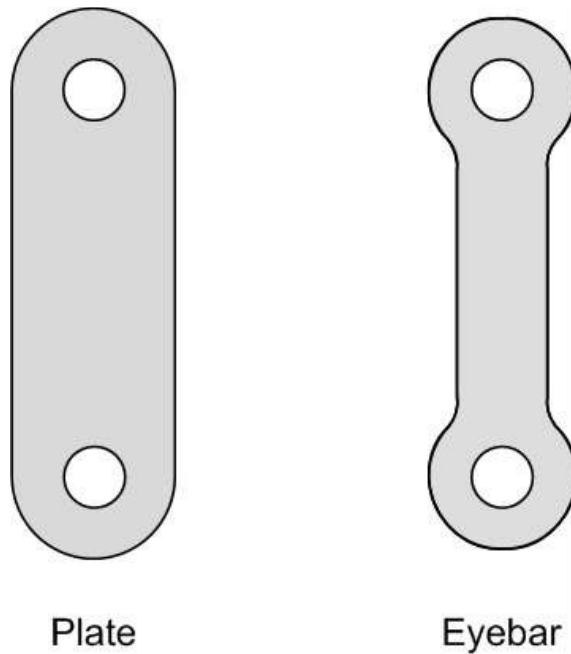

Figure 10.7.7 Plate Hanger and Eyebar Shape Hanger Link



Figure 10.7.8 Pin Cap, Through Bolt and Nut



Figure 10.7.9 Retaining Nut

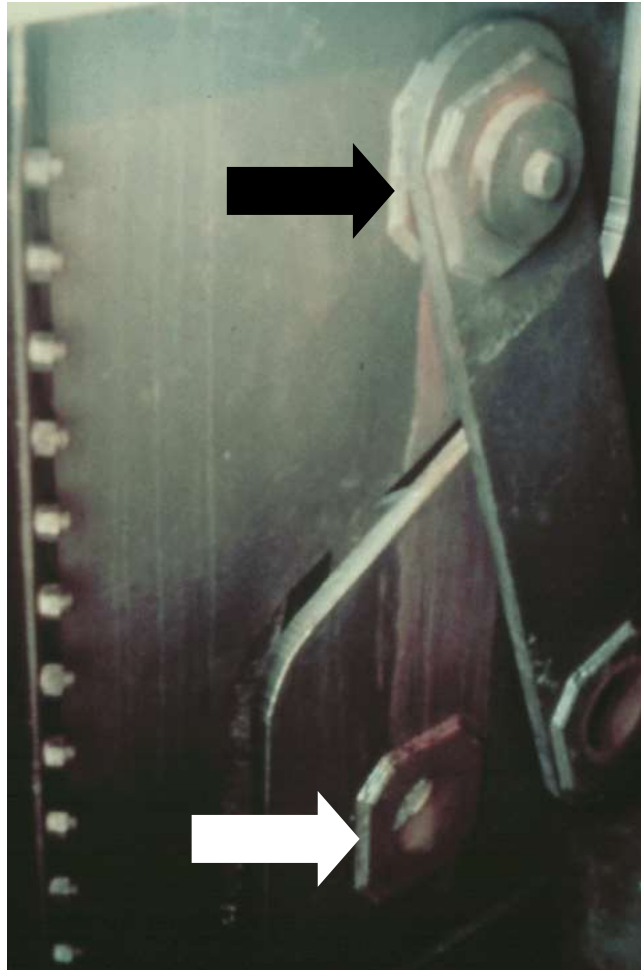

Figure 10.7.10 Web Doubler Plates

**Forces in a Pin
 – Design vs. Actual**

Some of the problems with the pin-and-hanger assembly can be attributed to deficiencies that cause forces that were not accounted for in the original design. The hanger or links are designed for pure tension forces only (see Figure 10.7.11). However, in actuality, hangers see both pure tension and bending. In-plane bending results from binding on the pins due to corrosion between the pin and the hanger (see Figure 10.7.12). Out-of-plane bending (perpendicular to the wide face) results from misalignment, pack rust, skewed geometry or improper erection.

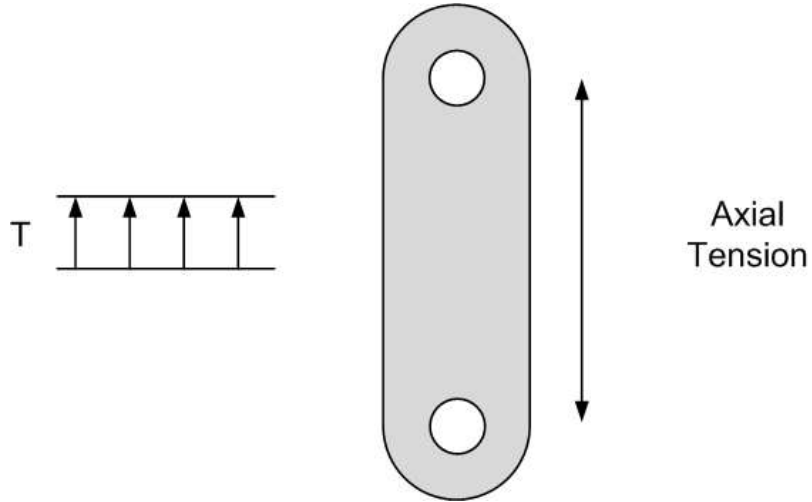

Figure 10.7.11 Design Stress in a Hanger Link(Tension Only)

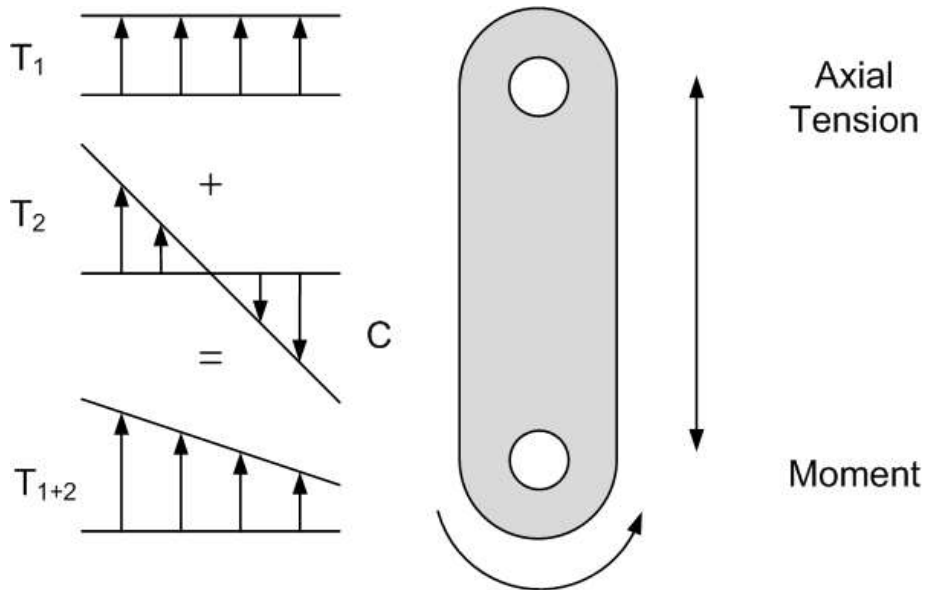

Figure 10.7.12 Actual Stress in a Hanger Link (Tension and Bending)

Pins are designed to resist shear and bearing on the full thickness of the hanger (see Figure 10.7.13). However, in addition to the designed forces, pins can see very high torsion (twisting) forces if they lose their ability to turn freely (see Figure 10.7.14). Section loss in the pin may cause a loss of bearing areas between the pin, the hangers and the web. This loss can cause unsymmetrical loading which results in possible out-of-plane bending in the web and hanger (see Figure 10.7.14).

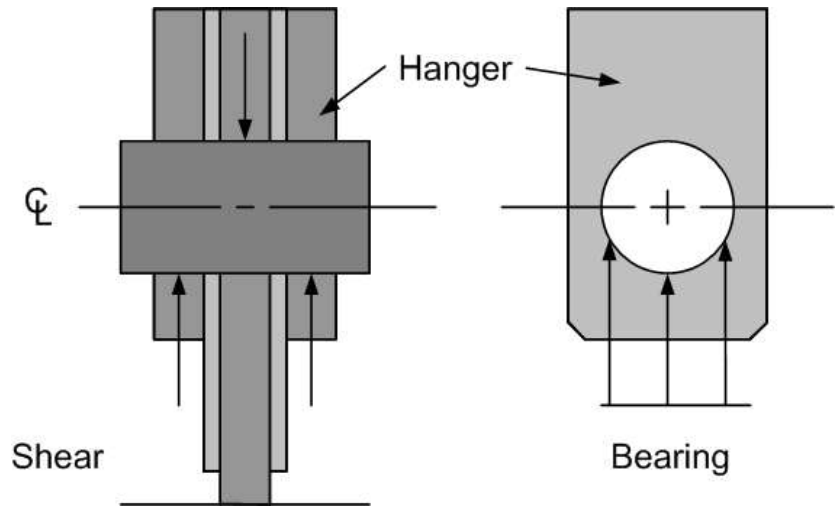

Figure 10.7.13 Design Stress in a Pin (Shear and Bearing)

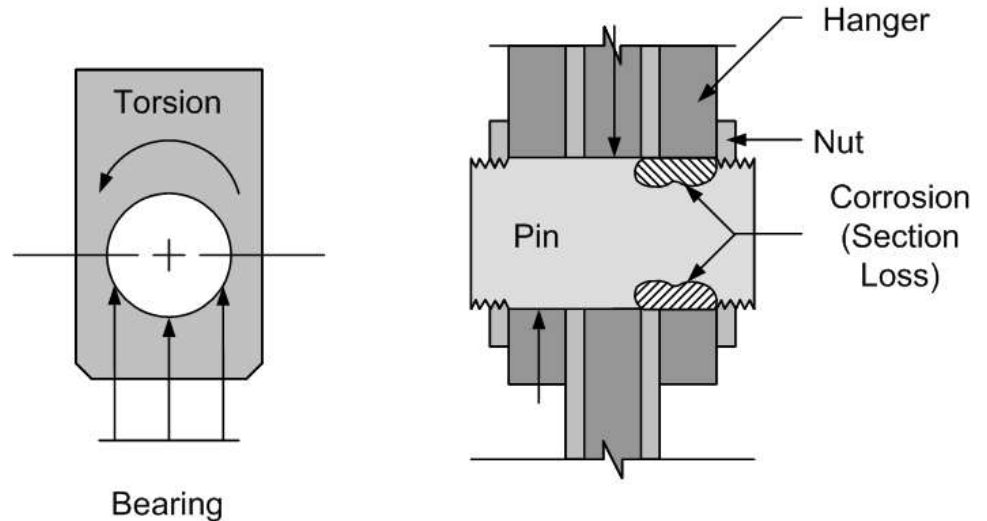

Figure 10.7.14 Actual Stress in a Pin (Shear, Bearing and Torsion)

Fracture Critical Pin-and-Hanger Assemblies

The *AASHTO Manual for Bridge Evaluation*, Section 4.8.3.11 states that when pin-and-hangers are present on trusses or two-girder systems, they are considered to be fracture critical. Therefore, it will be important to pay special attention during the inspection of pin-and-hanger connections when they are located in those types of superstructures. Failure of one pin or one hanger will cause collapse of the suspended span since there is no alternate load path. The collapse can be catastrophic as demonstrated by the Mianus River Bridge failure shown in Figure 10.7.15. The Mianus River Bridge failed due to the formation of rust between the hangers and the girder webs. As steel rusts, the rust can occupy up to 10 times the original steel volume causing unwanted expansion forces when in a confined space. When rust creates this type of expansion force, it is called “rust packing”. In the case of the Mianus River Bridge, the rust packing pushed the hangers to the ends of the deteriorated pins and the pins eventually failed in bearing. The failure may have been compounded by the heavily skewed geometry of the bridge that intensified the lateral force on the pin-and-hanger assembly.



Figure 10.7.15 Mianus River Bridge Failure

Pin-and-hanger assemblies in multi-girder structures are not technically fracture critical, since multiple load paths are available. However, they do have the potential for progressive collapse. If the pin-and-hanger assemblies at a joint location are frozen and consequently overstressed, the failure of one could cause an adjacent assembly to fail and so on (see Figure 10.7.16). Some bridge owners treat all pin-and-hanger assemblies as fracture critical, regardless of whether or not the girders they support are redundant.



Figure 10.7.16 Multi-girder Bridge with Pin-and-Hanger Assemblies

10.7.3

Overview of Common Deficiencies

Common deficiencies that occur on steel pin-and-hanger bridge assemblies are:

- Corrosion
- Fatigue cracking
- Overloads
- Collision damage
- Heat damage
- Coating failures

See Topic 6.3.5 for a detailed presentation of the properties of steel, types and causes of steel deterioration, and the examination of steel. Refer to Topic 6.4 for Fatigue and Fracture in Steel Bridges

10.7.4

Inspection Methods and Locations

Inspection methods to determine other causes of steel deterioration are discussed in detail in Topic 6.3.7.

Methods

Visual

The inspection of steel bridge members for defects is primarily a visual activity.

Most deficiencies in steel bridges are first detected by visual inspection. In order for this to occur, a hands-on inspection, or inspection where the inspector is close enough to touch the area being inspected, is required. More exact visual observations can also be employed using a magnifying unit after cleaning the suspect area.

Physical

Removal of paint can be done using a wire brush, grinding, or sand blasting, depending on the size and location of the suspected deficiency. Exercise care when clearing suspected areas that are cracked. When clearing steel surfaces avoid any type of clearing process that would tend to close discontinuities such as blasting. The use of degreasing spray before and after removal of the paint may help in revealing the deficiency.

When section loss occurs, use a wire brush, grinder or hammer to remove loose or flaked steel. After the flaked steel is removed, measure the remaining section and compare it to a similar section with no section loss.

The usual and most reliable sign of fatigue cracks is the oxide or rust stains that develop after the paint film has cracked. Experience has shown that cracks have generally propagated to a depth between one-fourth and one-half the plate thickness before the paint film is broken, permitting the oxide to form. This occurs because the paint is more flexible than the underlying steel.

Smaller cracks are not likely to be detected visually unless the paint, mill scale, and dirt are removed by carefully cleaning the suspect area. If the confirmation of a possible crack is to be conducted by another person, it is advisable not to disturb the suspected crack area so that re-examination of the actual conditions can be made.

Once the presence of a crack has been verified, examine any other similar locations and details on the bridge.

Advanced Inspection Methods

Several advanced methods are available for steel inspection. Nondestructive methods, described in Topic 15.3.2, include:

- Acoustic emissions testing
- Corrosion sensors
- Smart coatings

- Dye penetrant
- Magnetic particle
- Radiographic testing
- Computer tomography
- Robotic inspection
- Ultrasonic testing
- Eddy current
- Electrochemical fatigue sensor (EFS)

Other methods, described in Topic 15.3.3, include:

- Brinell hardness test
- Charpy impact test
- Chemical analysis
- Tensile strength test

Visual inspection of the pin may not be very effective. The majority of the pin is concealed inside the assembly and at best only the surface is available for inspection. Many internal flaws and defects can go undetected if an advanced inspection technique such as ultrasonic testing is not used.

Ultrasonic testing is currently the most common means available of checking pins in place (see Figure 10.7.17). For the results to be valid, careful planning and testing by trained, certified technicians is required. For a more detailed look at ultrasonic testing refer to Topic 15.3.

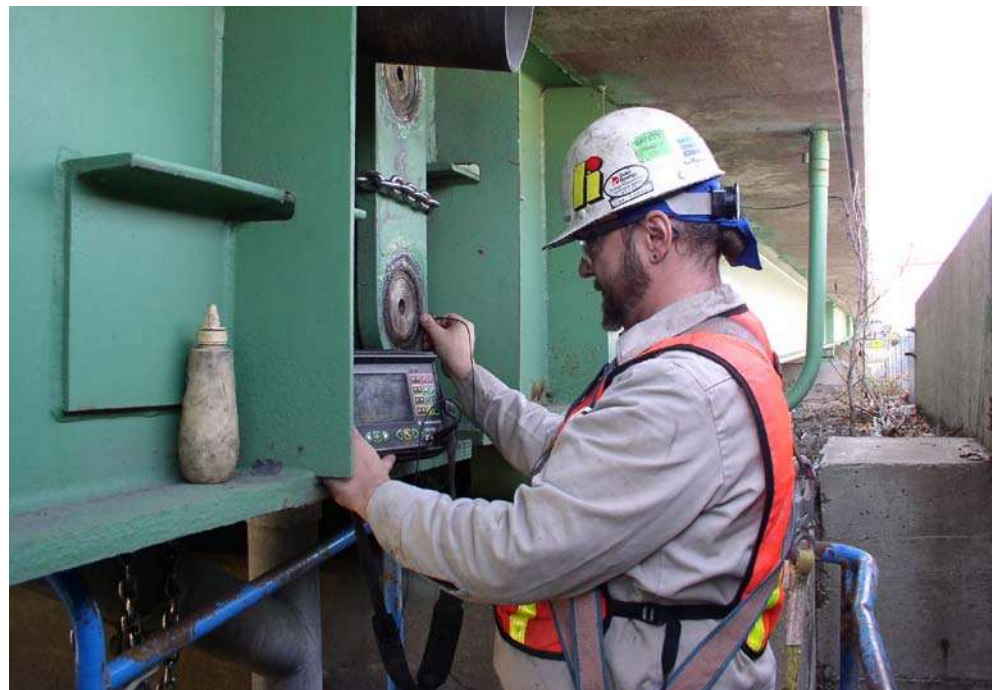

Figure 10.7.17 Ultrasonic Testing of a Pin

Another method for inspecting the pin is to disassemble the pin-and-hanger unit. Undertake the disassembly of a pin-and-hanger joint only after proper engineering design is performed and auxiliary support supplied. It is not a routine bridge inspection procedure (see Figure 10.7.18).



Figure 10.7.18 Alternate Hanger Link Retaining System

Hanger links and pins are often difficult to remove even after the retaining assemblies are taken off. This is not always true, however, and a pin on the verge of failure due to rust pack could fail suddenly when the nut is loosened.

Locations

General

Observe and record the general condition of the pin-and-hanger assembly. Check for alignment of the adjacent beam webs and flanges with a straight edge. If present, inspect the wind lock for signs of excessive transverse movement. A wind lock consists of steel or neoprene members attached to both the suspended and cantilever bottom flanges. It restricts differential latitudinal movement between the cantilevered and suspended girders. Note if deck drainage is entering the assembly.

Measure the actual dimensions between the pins and also the distance from each pin to the end of the hanger assembly and compare these values to the as-built dimensions (see Figure 10.7.19).

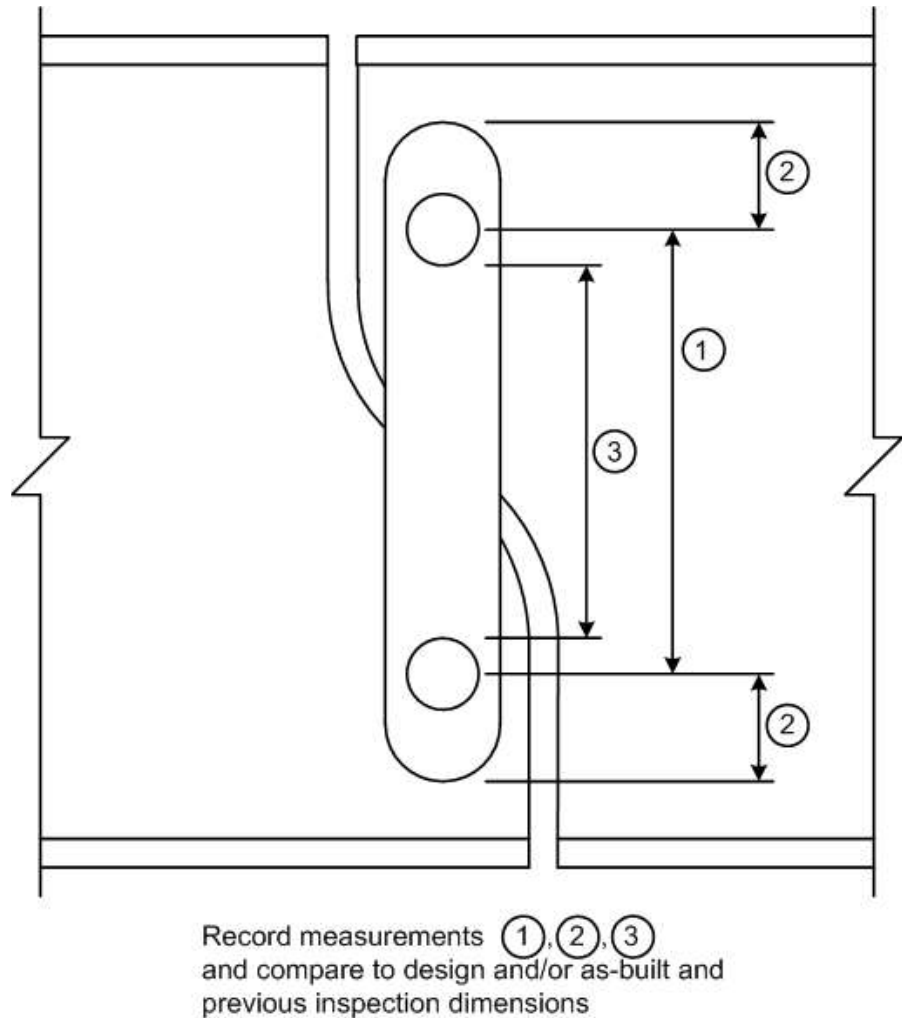

Figure 10.7.19 Pin Measurement Locations

Try to determine if movement is taking place. Corrosion can cause fixity at pin-and-hanger connections. This changes the structural behavior of the connection and is a source of cracking. Powdery red or black rust where surfaces rub indicates movement (see Figure 10.7.20). It may or may not indicate appreciable section loss. Where there is relative movement expected, an unbroken paint film across a surface indicates the pin is frozen.



Figure 10.7.20 Rust Stains from Pin Corrosion

Some movement due to traffic vibration may be observable. If this movement is excessive, or if there is significant vertical movement with live load passage, the pins or pin holes may be excessively worn.

Study the railing, expansion dam, beam ends, and any other structural components in the hinge area to see if any unusual displacements have taken place.

Hangers

Due to the rotation of the pins and hangers under live load and thermal expansion, they tend to incur wear over a period of time. Since portions of the assembly are inaccessible, they are not normally painted by maintenance crews and will, with time, begin corroding. This type of connection may be exposed to the elements and the spray of passing traffic. It may also be directly underneath an expansion dam where water and brine solutions may collect. This moist, corrosion-causing solution will slowly dry out, only to be reactivated during the next wet cycle.

Hangers are easier to inspect than pins since they are exposed and readily accessible. Try to determine whether the hanger-pin connection is frozen, as this can induce large bending moments in the hanger plates.

Examine accessible surface and edges closely for cracks (see Figure 10.7.21). The most critical areas are the ends beyond the pin centerlines and the juncture between the heads and shanks of eyebars. Note surface condition and section loss.



Figure 10.7.21 Corroded Hanger Plate

Assess the condition of the back side of the link by use of light and inspection mirror, if possible. Note the presence of corrosion. It may be helpful to probe with a wire or slender steel ruler.

Examine both sides of the plate for cracks due to bending of the plate from a frozen pin connection. Observe the amount of corrosion buildup between the webs of the girders and the back faces of the plates. Inspect the hanger plate for bowing or out-of-plane distortion from the webs of the girders (see Figure 10.7.22). Investigate any welds for cracks. If the plate is bowed, check carefully at the point of maximum bow for cracks that might be indicated by a broken paint film and corrosion.

Measure the distance between the back of the hanger and the face of the web at several locations. Compare these measurements from location to location and hanger to hanger. Variations greater than 1/8 inch could indicate twisting of the hanger bars or lateral movement due to rust packing. Carefully describe and record these measurements in permanent notes for comparison with as-built drawings and/or measurements taken at the next inspection.

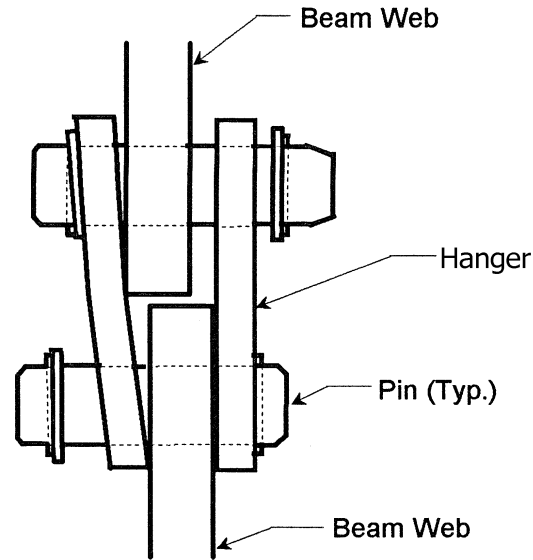

Figure 10.7.22 Bowing Due to Out of Plane Distortion of Hanger

Problematic Areas

The critical areas most likely to develop cracks are outlined below and shown in Figure 10.7.23:

- At welds used to connect hanger plates
- At welds used to connect web doubler plates
- In the base metal at the ends of hangers adjacent to pin holes
- In the base metal at the juncture between heads and shanks of eyebars

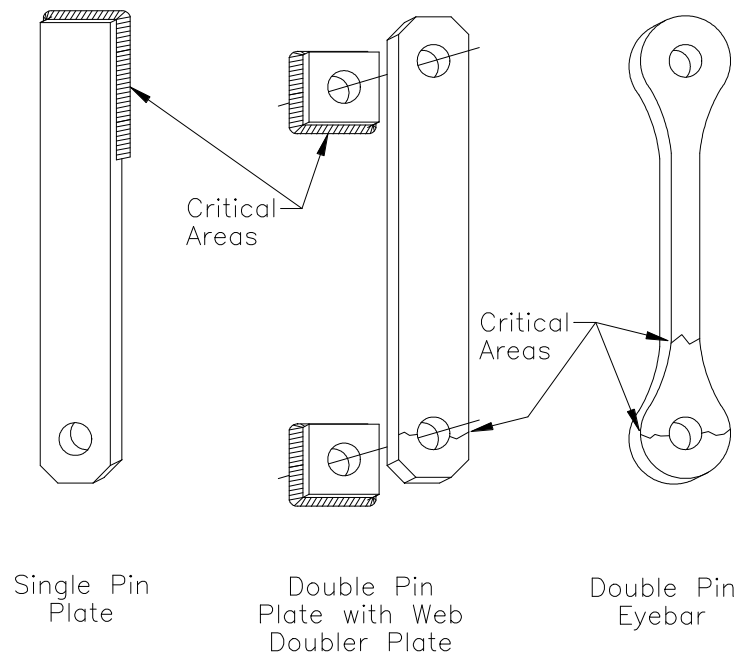

Figure 10.7.23 Fatigue Cracks in Pin-and-Hanger Assemblies

Pins

Rarely is the pin directly exposed in a pin-and-hanger assembly. As a result, its inspection is difficult but not impossible. By carefully taking certain measurements, the apparent wear can be determined. If more than 1/8 inch net section loss of the diameter has occurred, bring it to the attention of the bridge engineer at once (see Figure 10.7.24). Wear to the pins and hangers will generally occur in two locations: at the top of the pin and top of the hanger on the cantilevered span and at the bottom of the pin and the bottom of the hanger on the suspended span. Sometimes wear, loss of section, or lateral slippage may be indicated by misalignment of the deck expansion joints or surface over the hanger connection. When inspecting a pin-and-hanger assembly, locate the center of the pin, measure the distance between the center of the pin and the end of the hanger, and compare to the plan dimensions, if available. Remember to allow for any tolerances since the pin was not machined to fit the hole exactly. Generally, this tolerance will be 1/32 inch. If plans are not available, compare to previous measurements. The reduction in this length will be the apparent wear on the pin.

In a fixed pin and girder, wear will generally be on the top surface of the pin due to rotation from live load deflection and attractive forces. Locate the center of the pin, and measure the distance between the center of the pin and some convenient fixed point, usually the bottom of the top flange. Compare this distance to the plan dimensions to determine the decrease in the pin diameter.

Check the pin cap, if part of the assembly, with a straight edge for flatness.



Figure 10.7.24 Corroded Pin-and-Hanger Assembly

Retrofits

Since there are many problems associated with pin-and-hanger assemblies, several retrofit schemes have been devised to repair and/or provide redundancy in pin-and-hanger assemblies:

- Rod and saddle
- Underslung catcher
- Seated beam connection
- Continuity (field splice)
- Stainless steel replacements
- Non-metallic inserts and washers

The first two (rod & saddle and underslung catcher), are added to the structure and only carry load if the pin or hanger fails (see Figure 10.7.25). The gap between the “catcher” and the girder must be kept as small as possible to limit impact loading. If it is too tight, however, joint movement may be restrained. A neoprene bearing may be included in the assembly to lessen impact. Find out the relative design positions of the components and measure the critical points in the field for comparison.

The seated beam connection completely replaces the pin-and-hanger assemblies. Vacant pin holes may be left under some schemes. Inspection of these details will be the same as inspection at intersecting stiffeners and bearings.

Sometimes a pin-and-hanger assembly is retrofitted by using a bolted field splice. This is done only after a structural engineer analyzes the bridge to determine if the members can support continuous spans instead of cantilevered spans. Remember to inspect both the positive and negative moment regions of the superstructure. Additional deflections may be introduced into piers and more movements may take place at expansion bearings when continuity is introduced. Pay extra attention to these areas.



Figure 10.7.25 Underslung Catcher Retrofit

Replacing the pin-and-hanger assembly in kind with a structural grade of stainless steel eliminates potential failures due to corrosion related problems (see Figure 10.7.26). Placing a non-metallic insert and washer prevents corrosion between the pin and hanger and allows for normal rotation.



Figure 10.7.26 Stainless Steel Pin-and-Hanger Assembly

10.7.5

Evaluation

State and Federal rating guideline systems have been developed to aid in the inspection of pin-and-hanger assemblies. The two major rating guideline systems currently in use are the FHWA's *Recording and Coding Guide for the Structural Inventory and Appraisal of the Nation's Bridges* used for the National Bridge Inventory (NBI) component condition rating method and the *AASHTO Guide Manual for Bridge Element Inspection* for element level condition state assessment.

NBI Component Condition Rating Guidelines

Under NBI component condition rating guidelines, the pin-and-hanger assembly is considered part of the superstructure and does not have an individual rating. Take into account the condition of the pin-and-hanger assembly when rating the superstructure which may be lowered due to a deficiency in the pin and hanger. The superstructure is still rated as a whole unit but the pin and hanger may be the determining factor in the given rating.

Using NBI component condition rating guidelines, a one-digit code on the Federal Structure Inventory and Appraisal (SI&A) sheet indicates the condition of the superstructure. Component condition rating codes range from 9 to 0 where 9 is the best rating possible. See Topic 4.2 (Item 59) for additional details about NBI component condition rating guidelines.

Consider previous inspection data along with current inspection findings to determine the correct component condition rating.

Element Level Condition State Assessment

In an element level condition state assessment of a steel girder bridge with a pin-and-hanger assembly, possible AASHTO National Bridge Element (NBEs) and Bridge Management Elements (BMEs) are:

NBE No.

Description

Superstructure

161

Steel Pin, Pin-and-Hanger Assembly, or both

BME No.

Description

Wearing Surfaces and Protection Systems

515

Steel Protective Coating

The unit quantity for the pin-and-hanger assembly is each. Each pin-and-hanger element is placed in one of the four available condition states depending on the extent and severity of the deficiency. The unit quantity of protective coating is area, with the total area distributed among the four available condition states depending on the extent and severity of the deficiency. Condition State 1 is the best possible rating. See the *AASHTO Guide Manual for Bridge Element Inspection* for condition state descriptions.

The following Defect Flags are applicable in the evaluation of pin-and-hanger assemblies:

<u>Defect Flag No.</u>	<u>Description</u>
356	Steel Cracking/Fatigue
357	Pack Rust
362	Superstructure Traffic Impact (load capacity)
363	Steel Section Loss

See the AASHTO *Guide Manual for Bridge Element Inspection* for the application of Defect Flags.

This page intentionally left blank.

Table of Contents

Chapter 10 Inspection and Evaluation of Steel Superstructures

10.8 Gusset Plates	10.8.1
10.8.1 Introduction.....	10.8.1
10.8.2 Design Characteristics.....	10.8.4
Gusset Plates Connecting Primary Members	10.8.4
Resistance of Fasteners	10.8.6
Resistance of Gusset Plates.....	10.8.6
Gusset Plates in Tension.....	10.8.6
Gusset Plates in Shear	10.8.7
Gusset Plates in Compression	10.8.9
Gusset Plates under Combined Flexural and Axial Loads.....	10.8.10
Gusset Plates Connecting Secondary Member.....	10.8.11
10.8.3 Overview of Common Deficiencies.....	10.8.12
10.8.4 Inspection Methods and Locations	10.8.12
Methods	10.8.12
Visual	10.8.12
Physical.....	10.8.12
Advanced Inspection Methods.....	10.8.13
Locations	10.8.14
General.....	10.8.14
Areas with Corrosion	10.8.15
Areas with Section Loss	10.8.15
Areas Susceptible to Fatigue Cracking	10.8.21
Areas with Tack Welds	10.8.22
Areas Subject to Overstress	10.8.23
Areas with Paint Failure.....	10.8.24
Loose, Missing or Deteriorated Fasteners.....	10.8.25
Areas with Repairs and Retrofits	10.8.26
Areas with Out-of-Plan Distortion.....	10.8.28
10.8.5 Evaluation	10.8.30
NBI Component Condition Rating Guidelines.....	10.8.30
Element Level Condition State Assessment.....	10.8.30
10.8.6 Reasons to Inspect.....	10.8.32

This page intentionally left blank

Topic 10.8 Gusset Plates

10.8.1

Introduction

Gusset plates are used to connect multiple superstructure members together. They may connect primary load-carrying members, namely truss and arch members (see Figures 10.8.1 and 10.8.2), or secondary (bracing) members. Gusset plates are constructed from steel plates, which may be arranged in pairs or as a single plate, and are fastened to the members through riveting, bolting, welding or a combination of these methods (see Figures 10.8.3 through 10.8.5). Gusset plates are considered fracture critical members themselves when they connect one or more fracture critical members.

Although typically used to connect steel truss or arch superstructure members, gusset plates may also be used to connect timber truss or arch superstructure members, which includes using gusset plates for timber superstructure repairs and retrofits (see Figure 10.8.6).



Figure 10.8.1 Steel Truss Superstructure with Gusset Plates



Figure 10.8.2 Steel Deck Arch Superstructure with Stiffening Truss and Gusset Plates

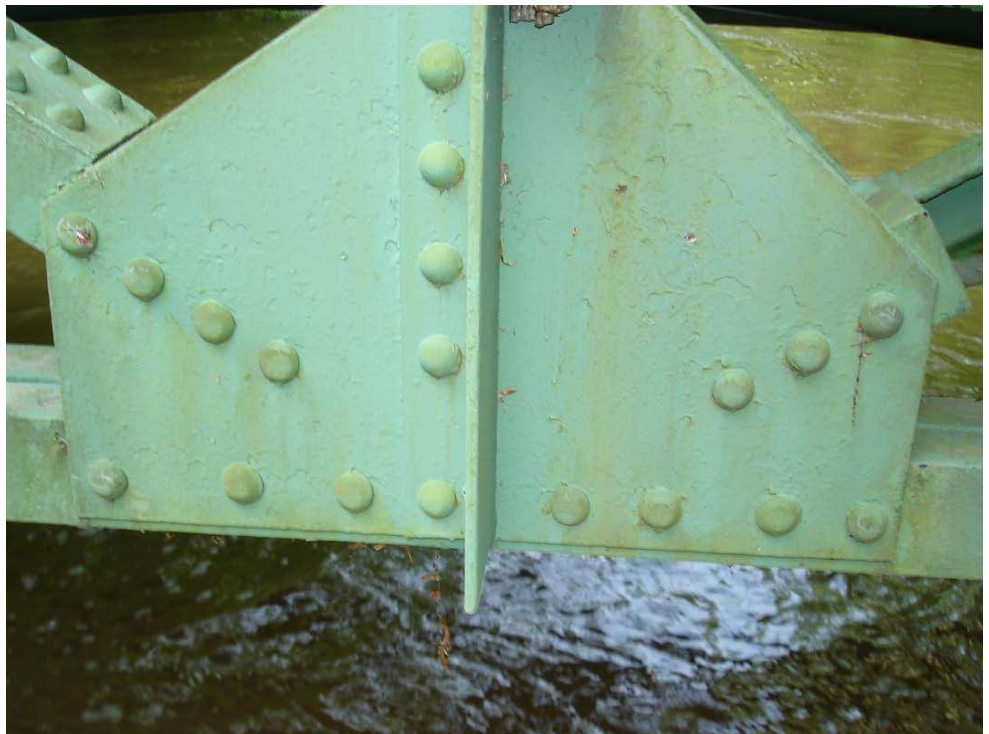

Figure 10.8.3 Steel Gusset Plate with Riveted Connections



Figure 10.8.4 Steel Gusset Plate with Welded Connections



Figure 10.8.5 Steel Gusset Plate with Riveted, Bolted and Welded Connections



Figure 10.8.6 Steel Gusset Plates Connecting Timber Primary Truss Members

10.8.2

Design Characteristics

Gusset plates may connect primary load-carrying members or secondary (bracing) members.

Gusset Plates Connecting Primary Members

Gusset plates are often the principal means of connecting primary load-carrying members together at panel points for truss and arch superstructures. Gusset plates used for these applications may connect two to more members together (see Figure 10.8.7); though connections between three to five members are most common (see Figure 10.8.8). Types of primary load-carrying members connected with gusset plates include the following:

- Truss top chords
- Truss bottom chords
- Truss web members (vertical and diagonal members)
- Arch members (main arch members and tie members)
- Arch struts or vertical members

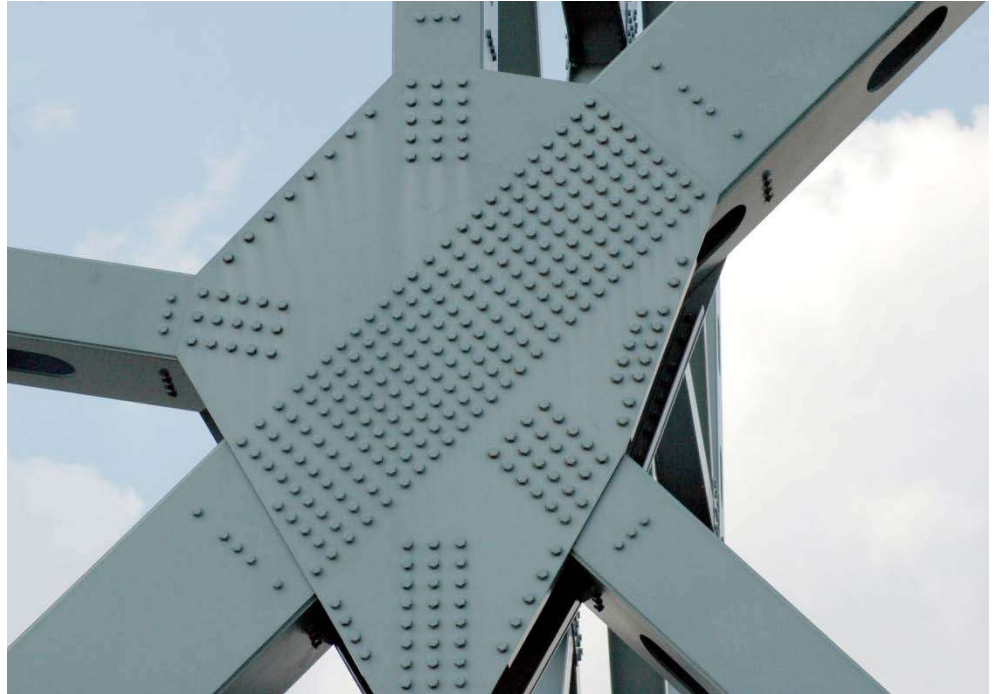

Figure 10.8.7 Odd-Shaped Gusset Plate Connecting Primary Load-Carrying Truss Members



Figure 10.8.8 Gusset Plate Connecting Primary Load-Carrying Truss Members

Gusset plates connecting primary load-carrying members are responsible for resisting various combinations of forces and stresses. Since gusset plates provide a connection between two or more members, the internal forces developed within

the gusset plates may be extremely complex. For this reason, the inspection of gusset plates is a very careful and detail-oriented procedure. In an effort to better understand the potential failure modes of gusset plates, it is important that bridge inspectors familiarize themselves with the gusset plate design criteria.

Gusset plate design is broken down into two different categories: resistance of fasteners and resistance of gusset plates.

Resistance of Fasteners

Gusset plate fasteners are generally either bolts or rivets, though a combination of the two may be observed in the field. The bolts and rivets in gusset connections are evaluated to prevent shearing and plate bearing failures. The strength of bolts is typically found on the design plans. Because gusset plates incorporating riveted connections were often constructed before construction records were maintained, the information regarding the strength of the rivets used in construction may not be available. Many Bridge Owners specify guidance for the strength of rivets according to the year of construction.

Resistance of Gusset Plates

Gusset plates resist tension, shear, compression, and combined flexural and axial loads.

Gusset Plates in Tension

Gusset plates subjected to axial tension are investigated for three conditions:

- Yield on the gross section - The resistance of the gusset plate is calculated using the gross cross-sectional area of the member and yield strength of the gusset plate.
- Fracture on the net section - The resistance of the gusset plate is calculated using the net cross-sectional area (accounting for bolt holes and the effective width of the gusset plate) and the tensile strength of the plate.
- Block shear rupture - The resistance of the gusset plate is calculated from the combined resistance of parallel and perpendicular planes; one in axial tension and the others in shear. Examples of potential block shear rupture planes for gusset plates in tension are illustrated in Figure 10.8.9.

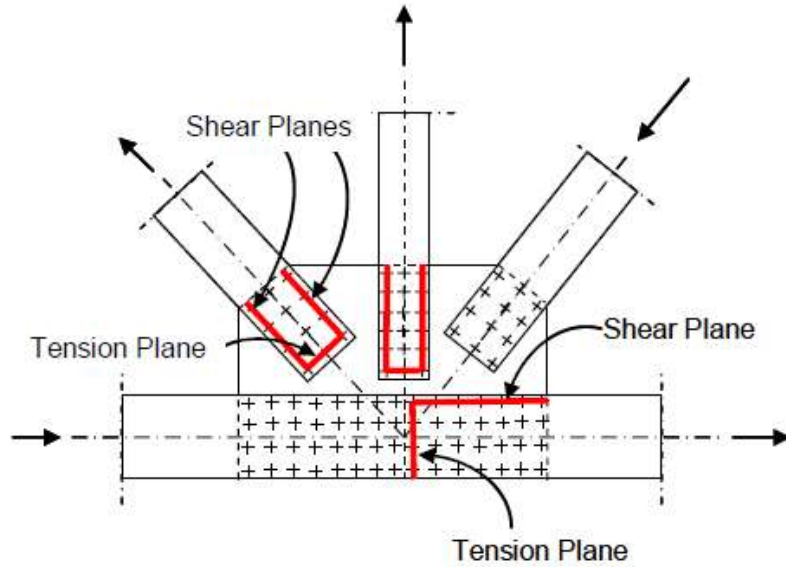

Figure 10.8.9 Potential Block Shear Rupture Planes for Gusset Plates in Tension

Gusset Plates in Shear

Gusset plates subject to shear are investigated for two conditions:

- Gross section shear yielding - The shear resistance of the gusset plate is calculated using the gross cross-sectional area of the member, yield strength of the gusset plate, and the shear resistance. Examples of gross section shear yielding planes are illustrated in Figure 10.8.10.
- Net section shear fracture - The shear resistance of the gusset plate is calculated using the net cross-sectional area, tensile strength of the plate, and the shear resistance. Examples of net section shear yielding planes are illustrated in Figure 10.8.11.